



# X翼星际战机 X-WING STARFIGHTER IP034-ARG

# 拼装说明书

## 拼装提示 TIPS:

本产品采用扣点与扣位卡扣拼折的拼装方式，未发生拼装损坏，无需使用胶水 

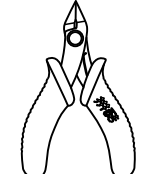
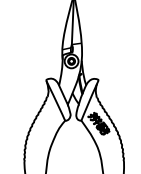
建议购买并使用拼酷正品拼装工具， T-SKQ05 水口钳  ， T-JZQ05 尖嘴钳  ， 拼装更省时省力，作品更精细美观！

请参照包装内说明书进行拼装，请勿反复拼折金属零件，以免损坏。

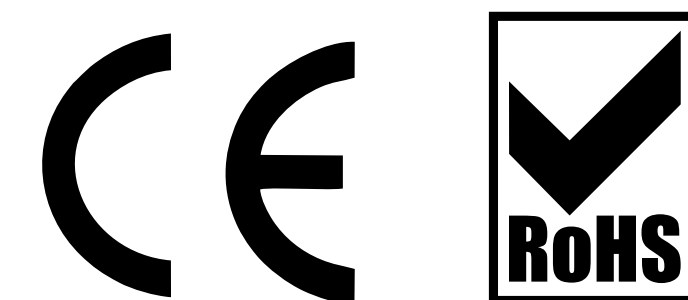

## AGES 14+

本产品为金属制品，14岁以下需由成人陪同完成！



### X翼星际战机 X-WING STARFIGHTER IP034

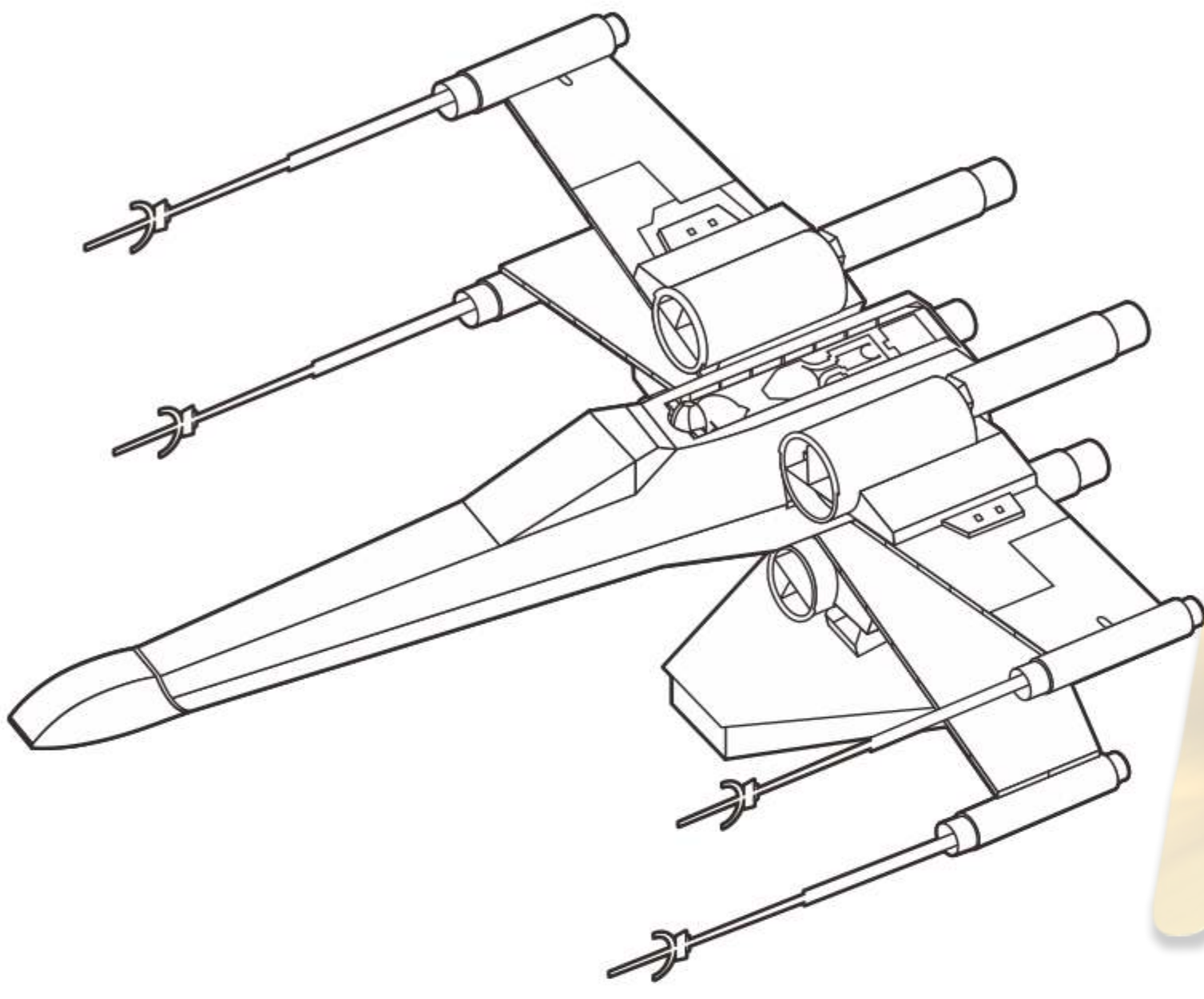

CP-ASSY-IP034-A1-20200407

#### 拼前需知

##### • 准备工具：

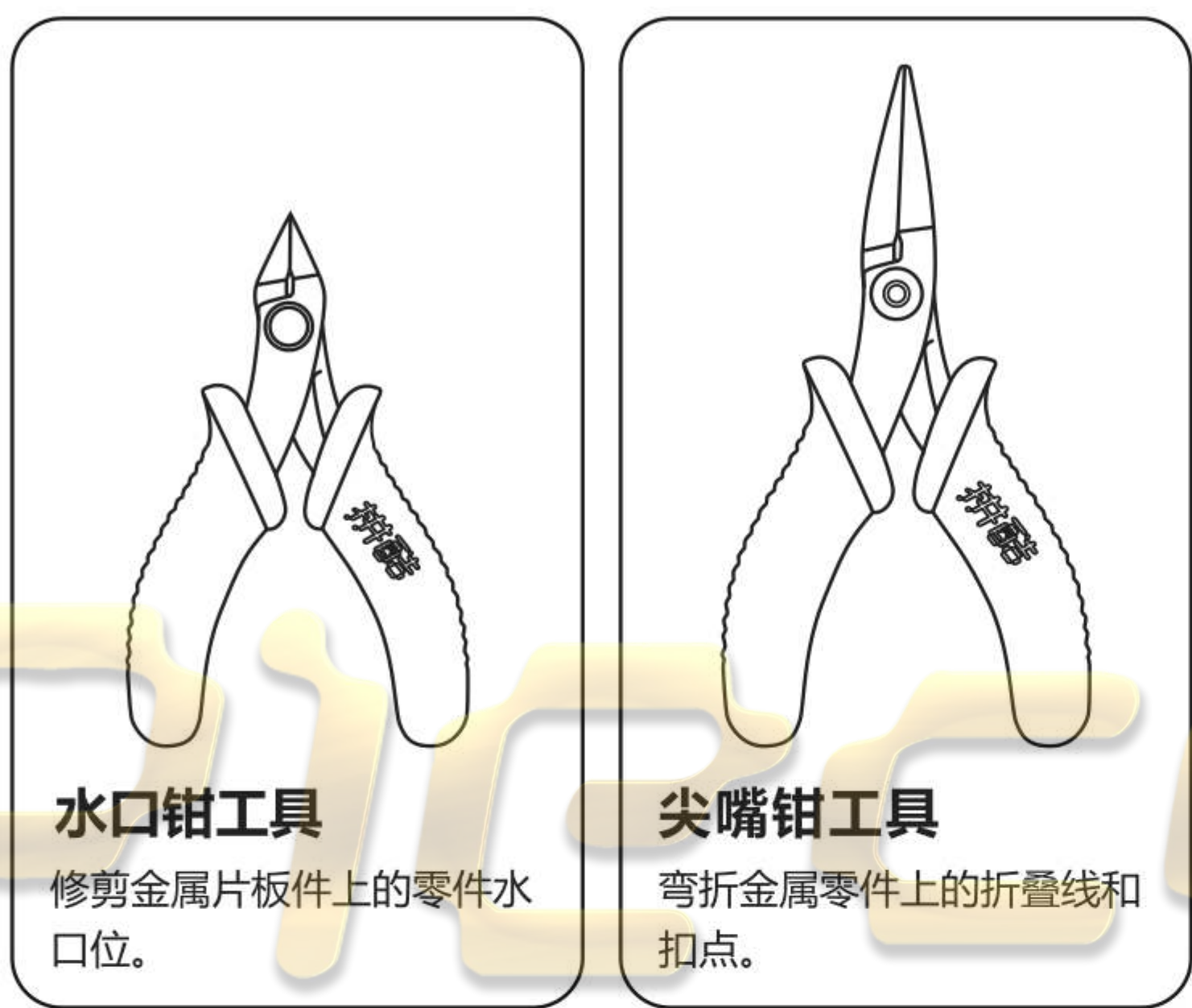

水口钳工具

修剪金属片板件上的零件水口位。

尖嘴钳工具

弯折金属零件上的折叠线和扣点。

建议使用拼酷正品拼装工具（水口钳、尖嘴钳），拼装时更省心、省力，拼装后作品更精细、美观！

⚠️ 请小心处理金属边料，以防划伤

##### • 拼装方法：

###### a. 取下零件



使用水口钳剪断金属零件上的水口，将需要的金属零件从金属片板上取下。

###### b. 识别零件



识别金属零件上的扣点、折叠线、扣孔的样子。

###### c. 折叠零件

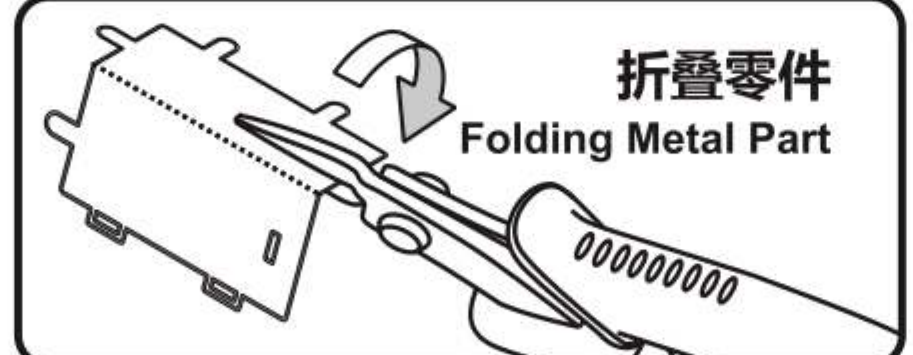

使用尖嘴钳，参照拼装说明书将金属零件折成形状。

###### d. 固定零件



● 插入扣孔，平折 90°



▲ 插入扣孔，旋转 90°

##### • 注意事项：



剪金属零件时请剪零件“水口位”，请勿将“扣点”当成“水口位”剪下，每次剪零件时请仅剪当前步骤的零件，切勿一次性将所有零件全部剪下，避免丢失；  
当遇到折叠线的零件，请注意金属片的正反面及拼折方向，请按照说明书说明的方向，轻剪慢折，最好一次折叠完成，请勿反复折叠，避免零件损坏。

#### 拼装步骤

##### Step 1

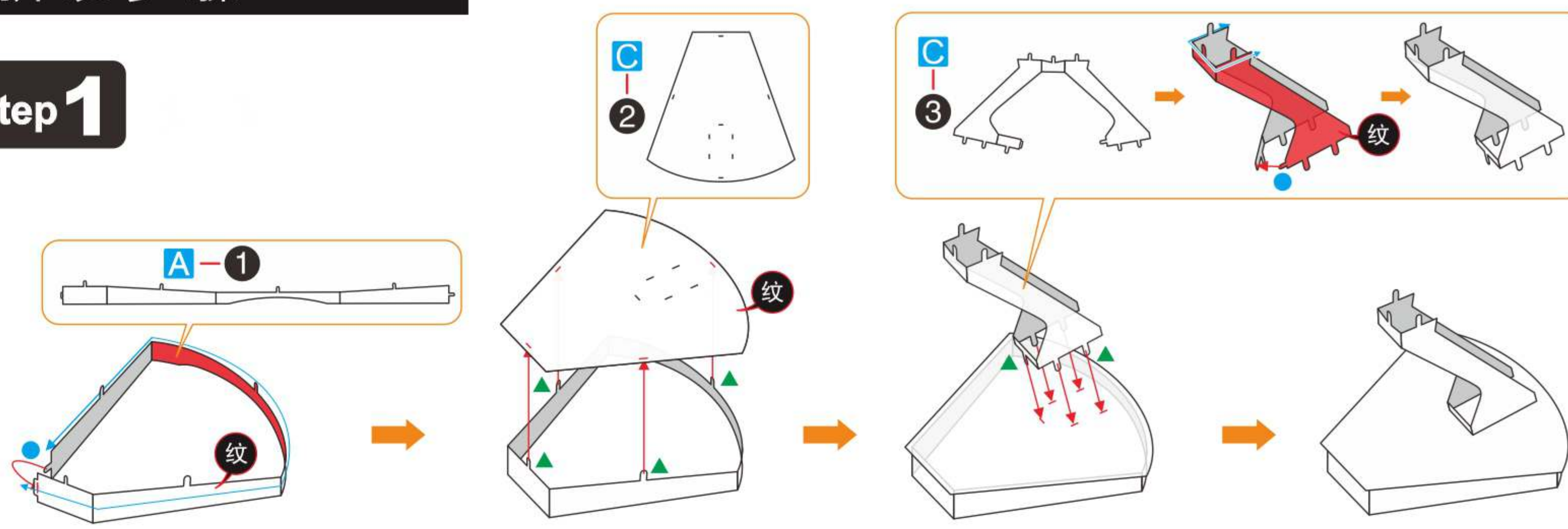

##### Step 2

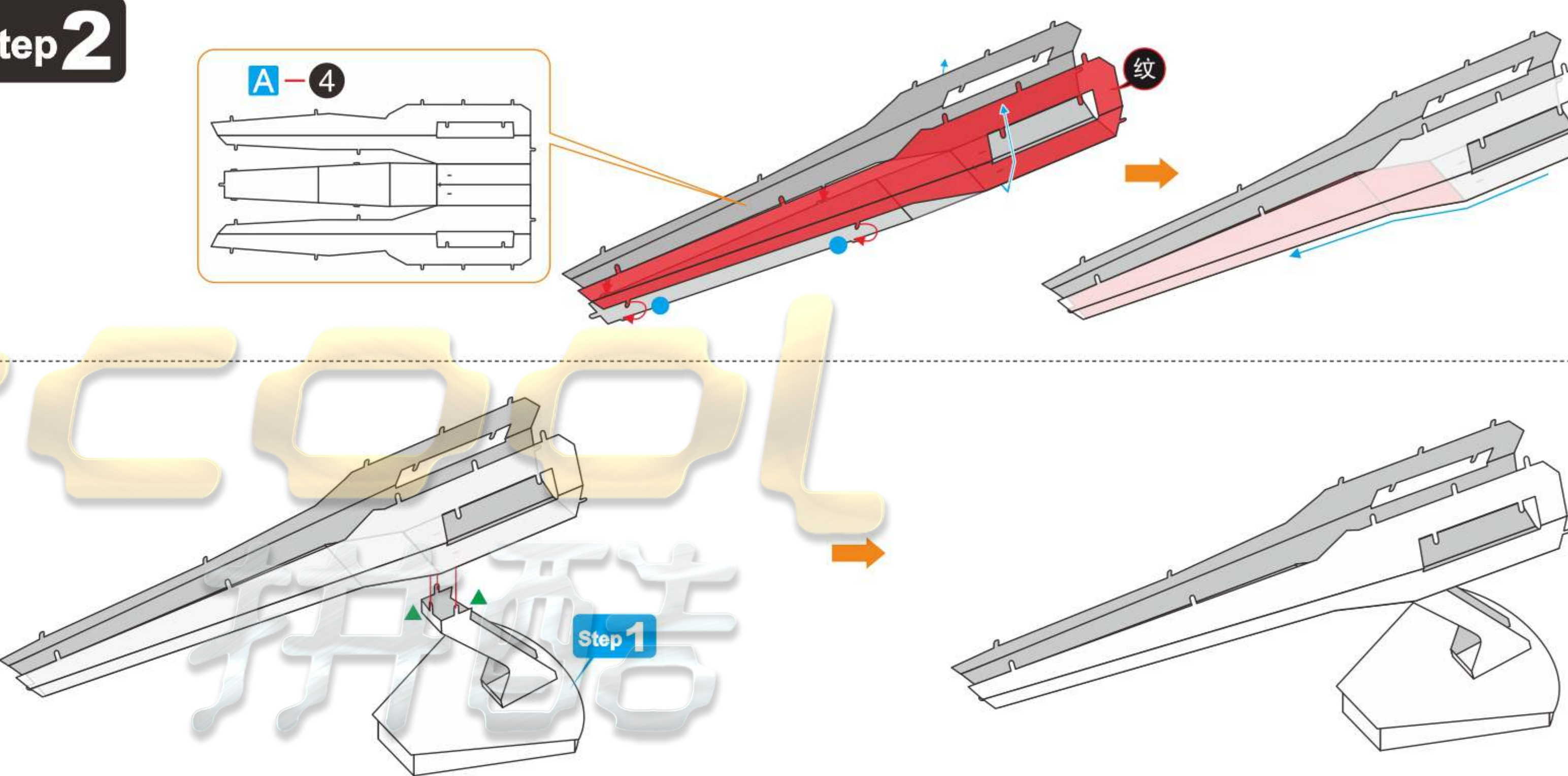

##### Step 3

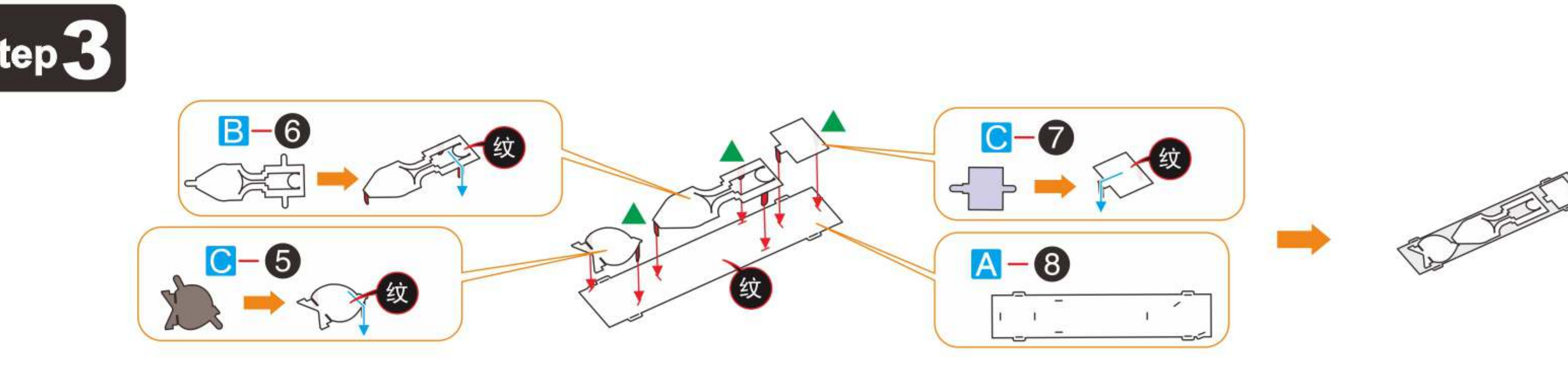

##### Step 4

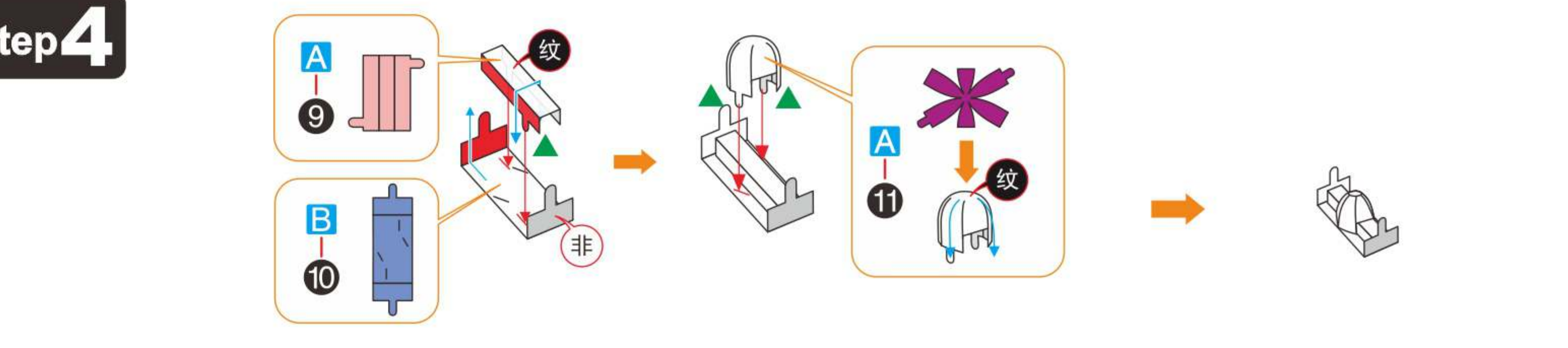

##### Step 5

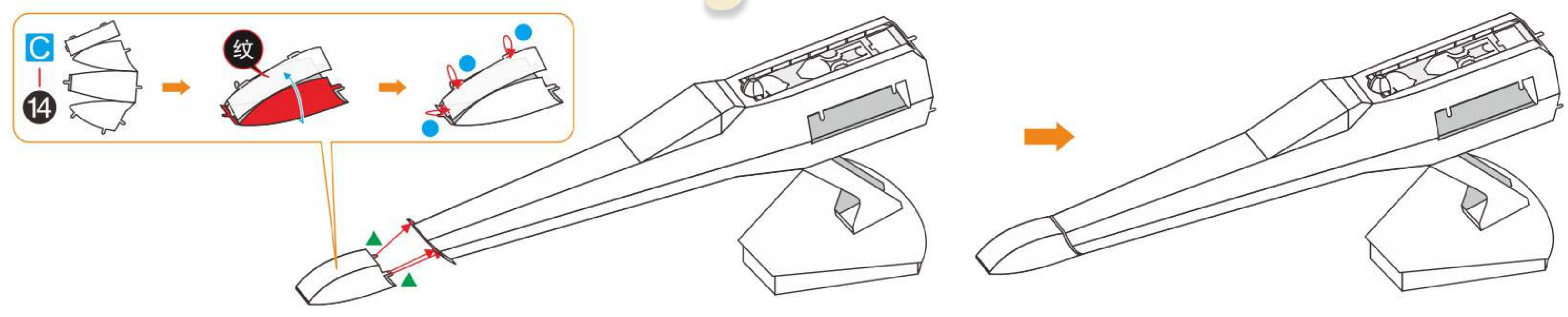
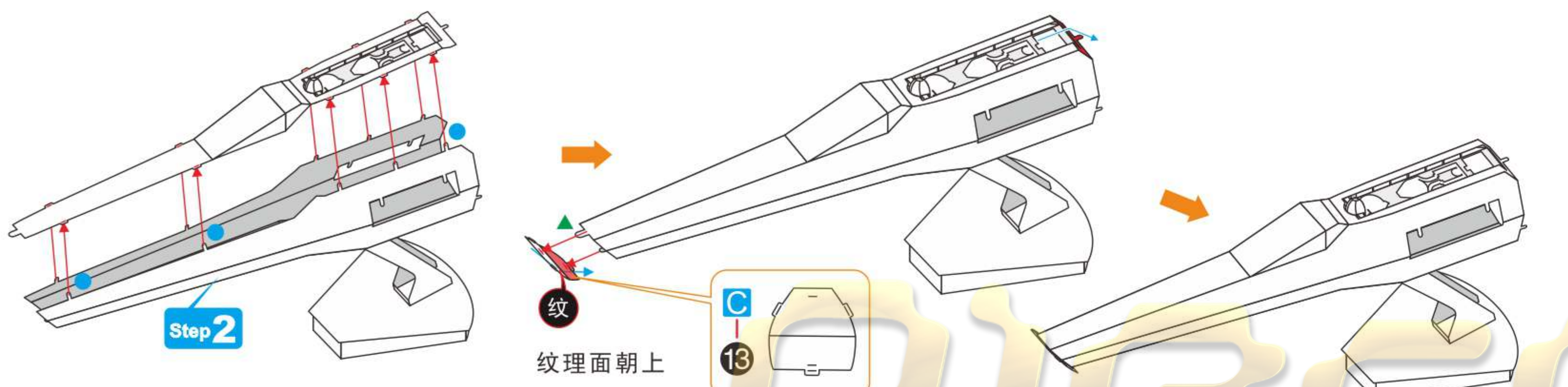
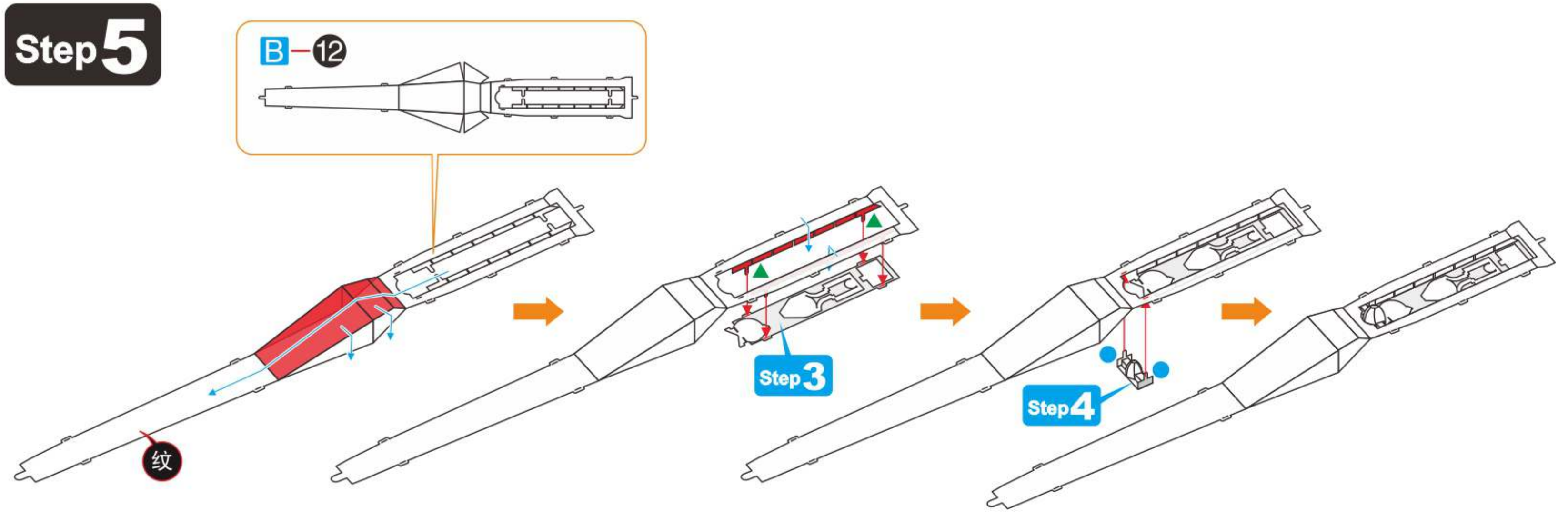

##### Step 6

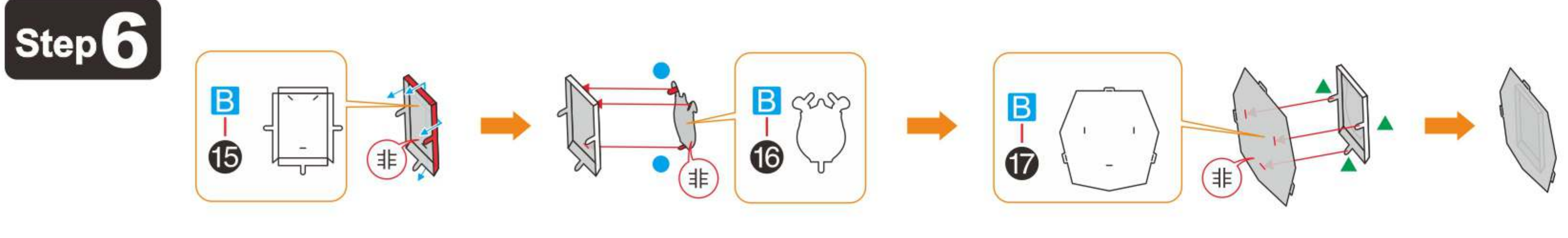

##### Step 7

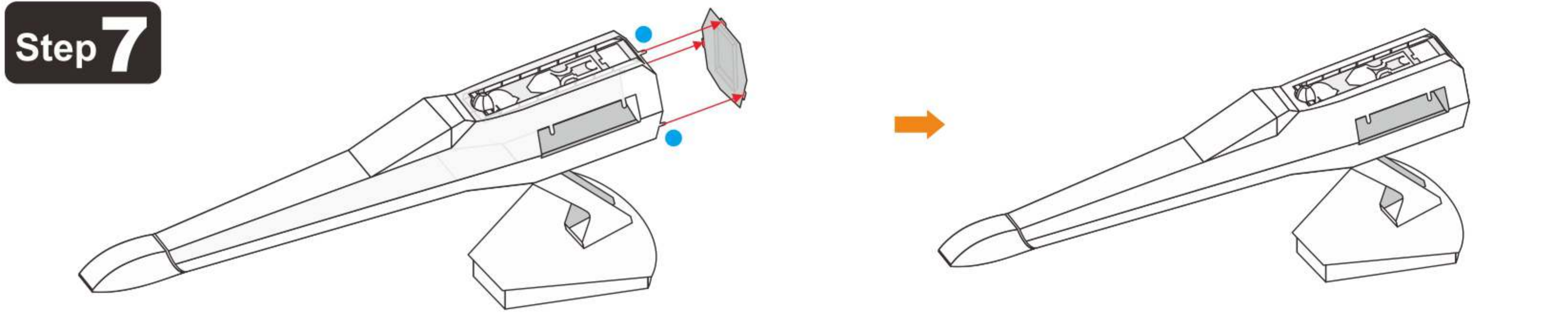

##### Step 8

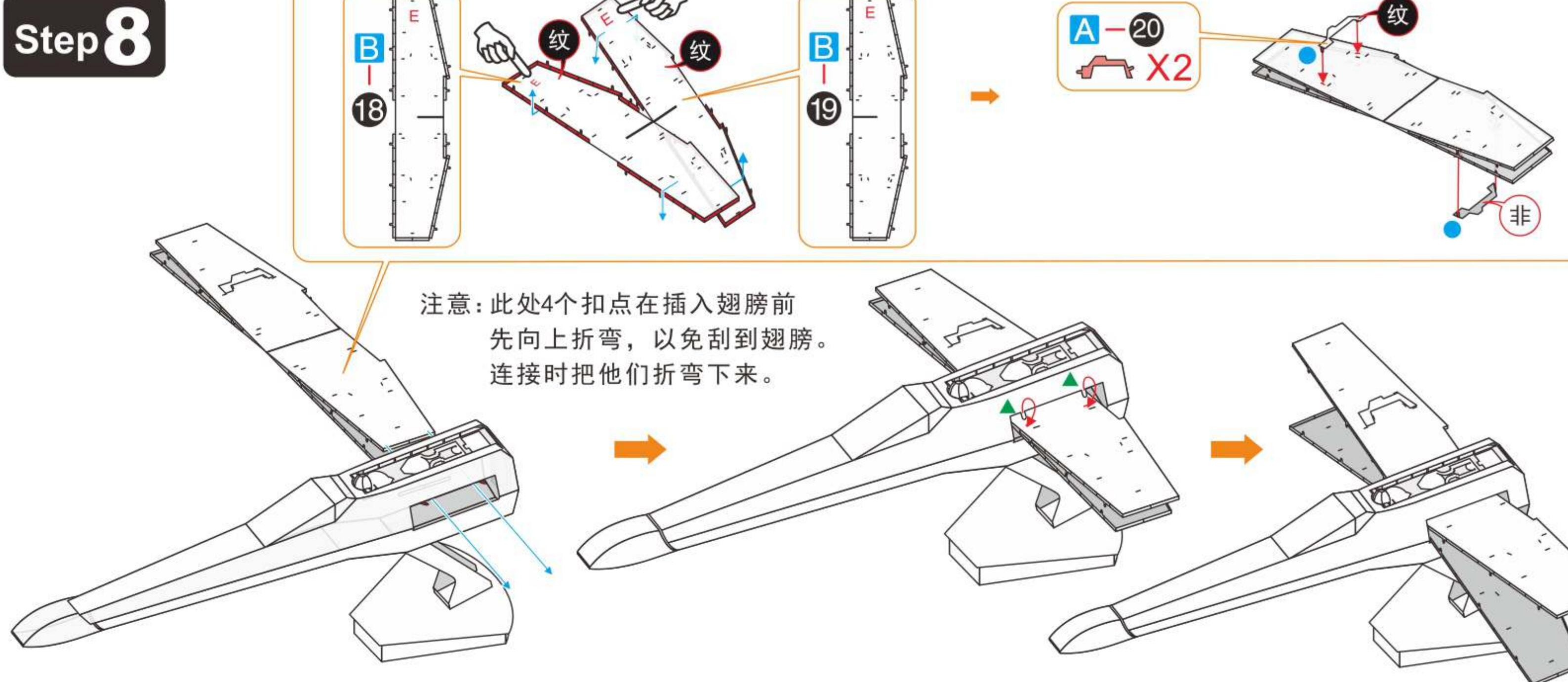

##### Step 9

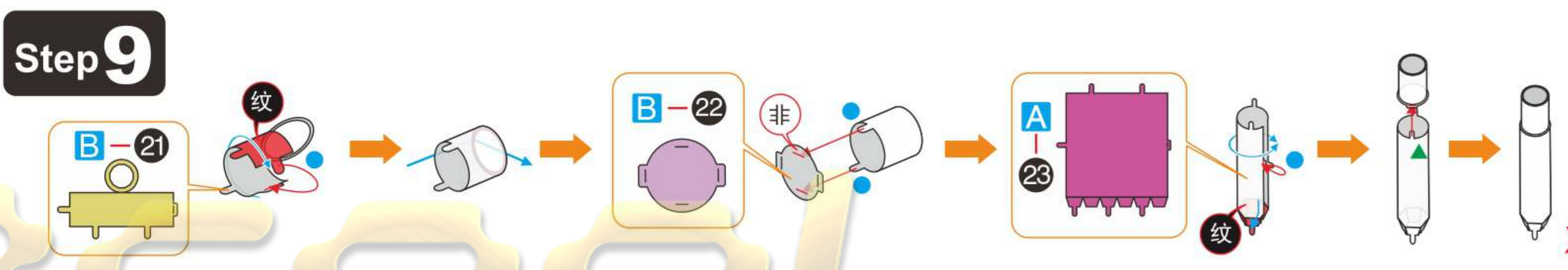

##### Step 10

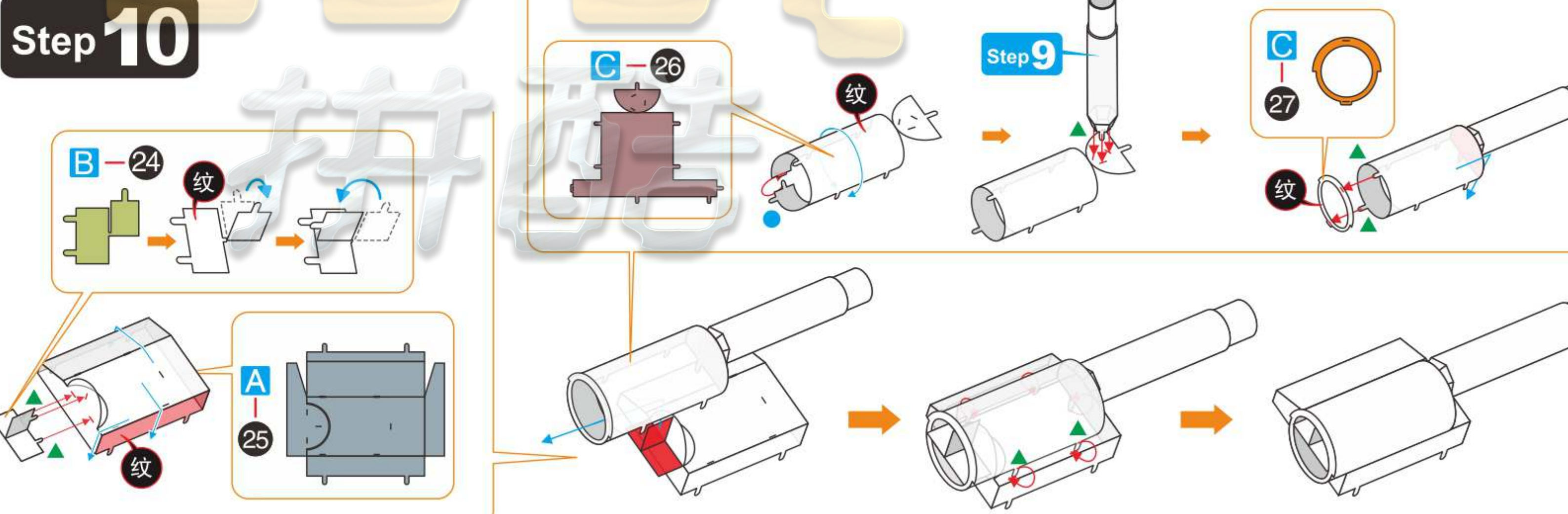

##### Step 11

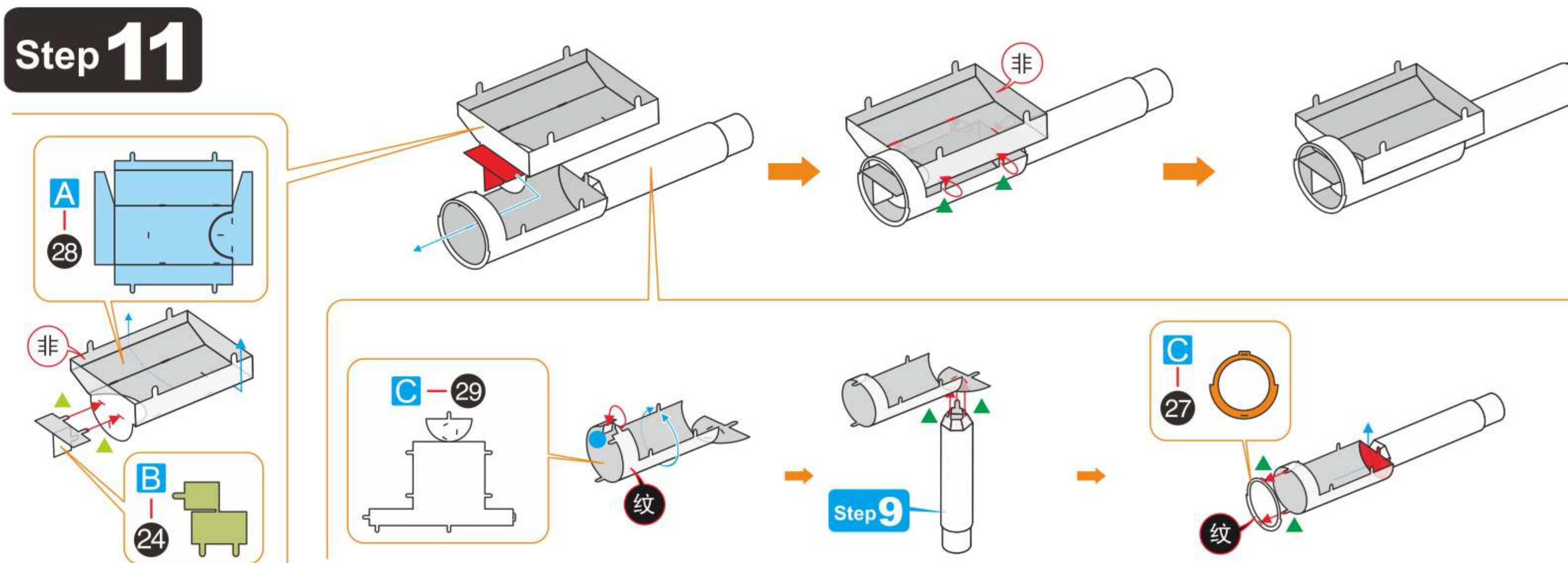



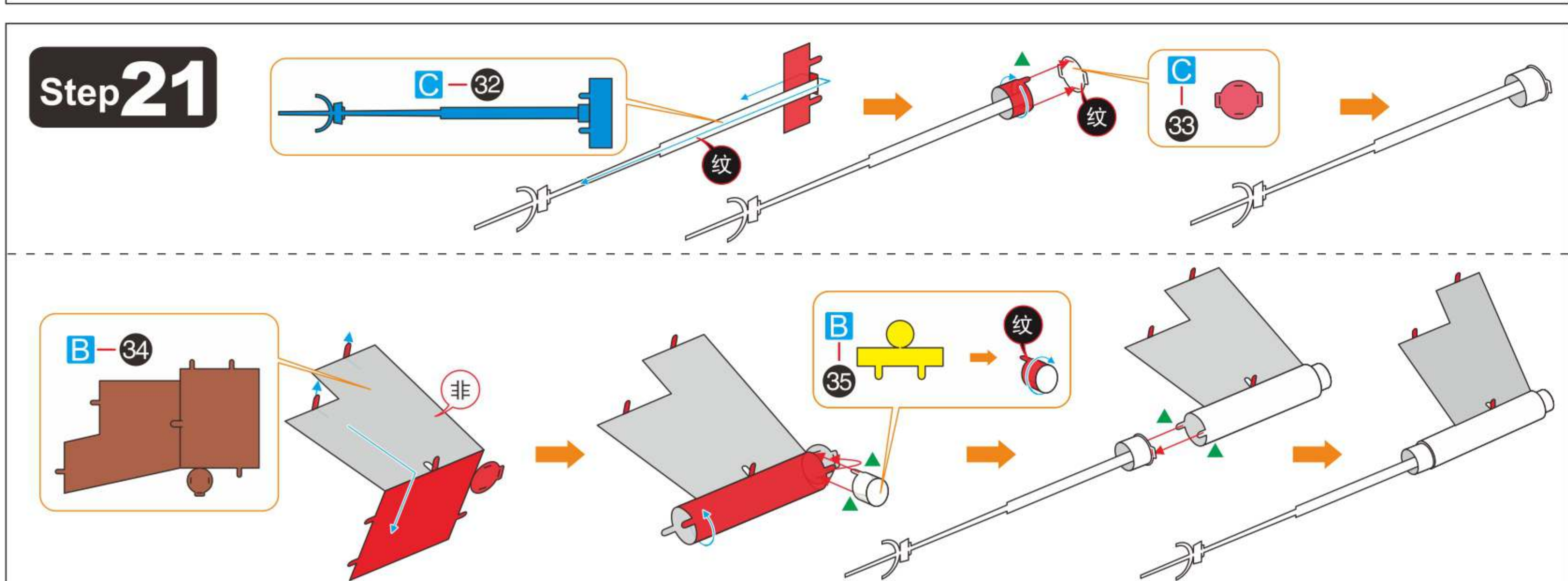
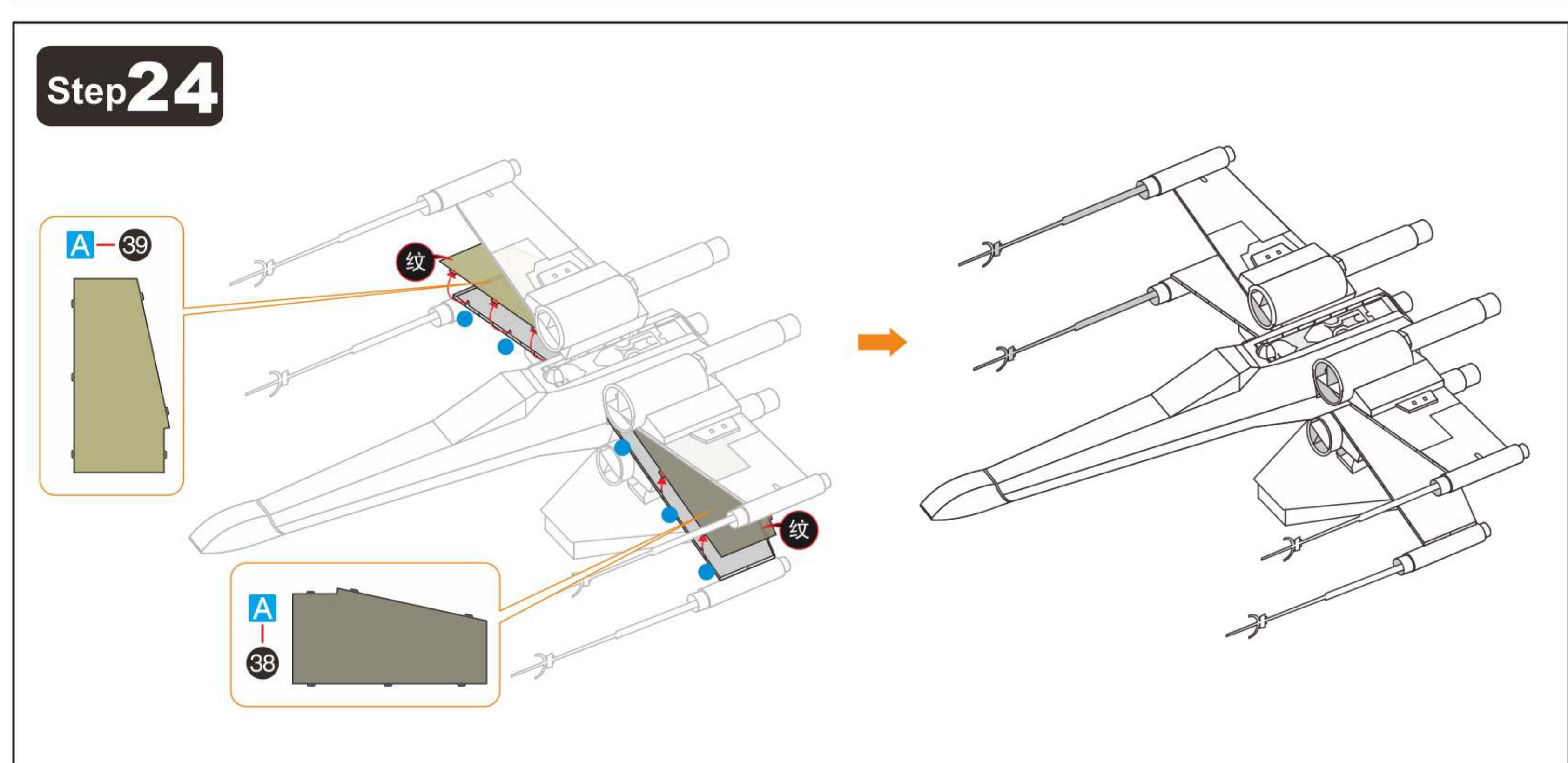
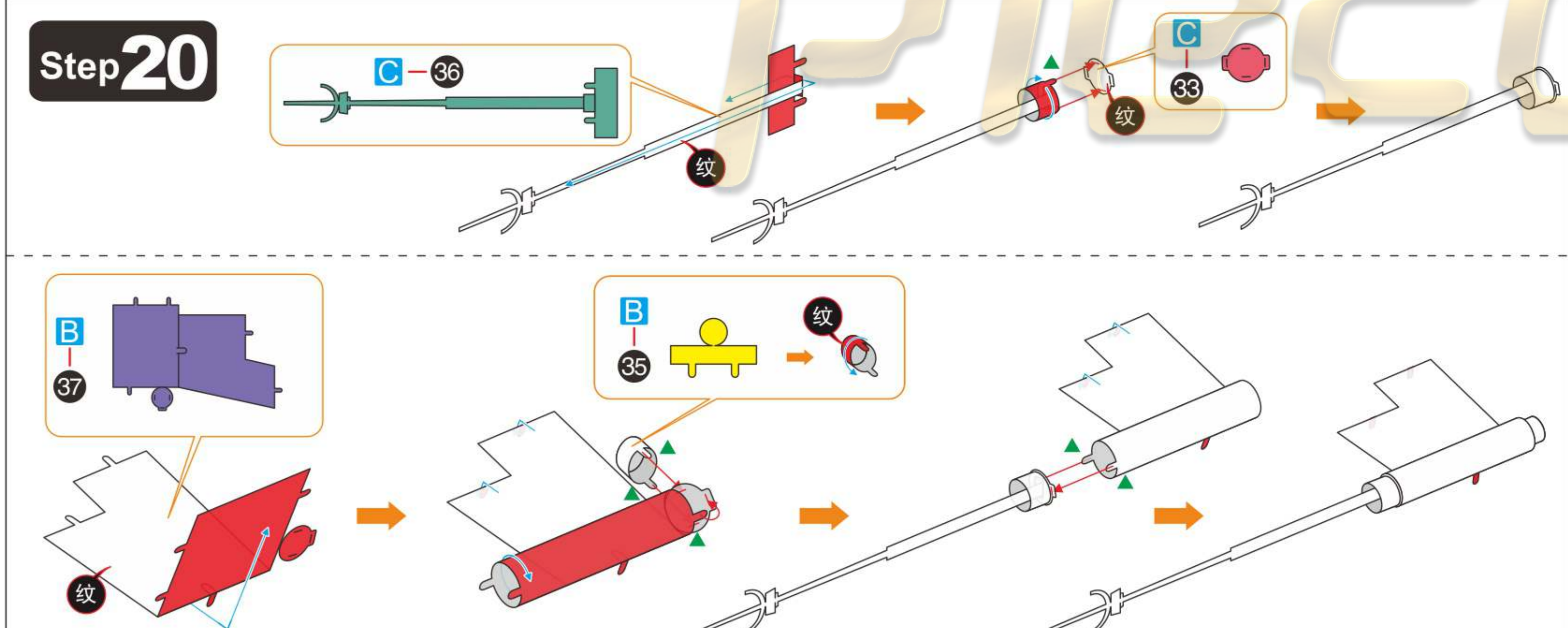
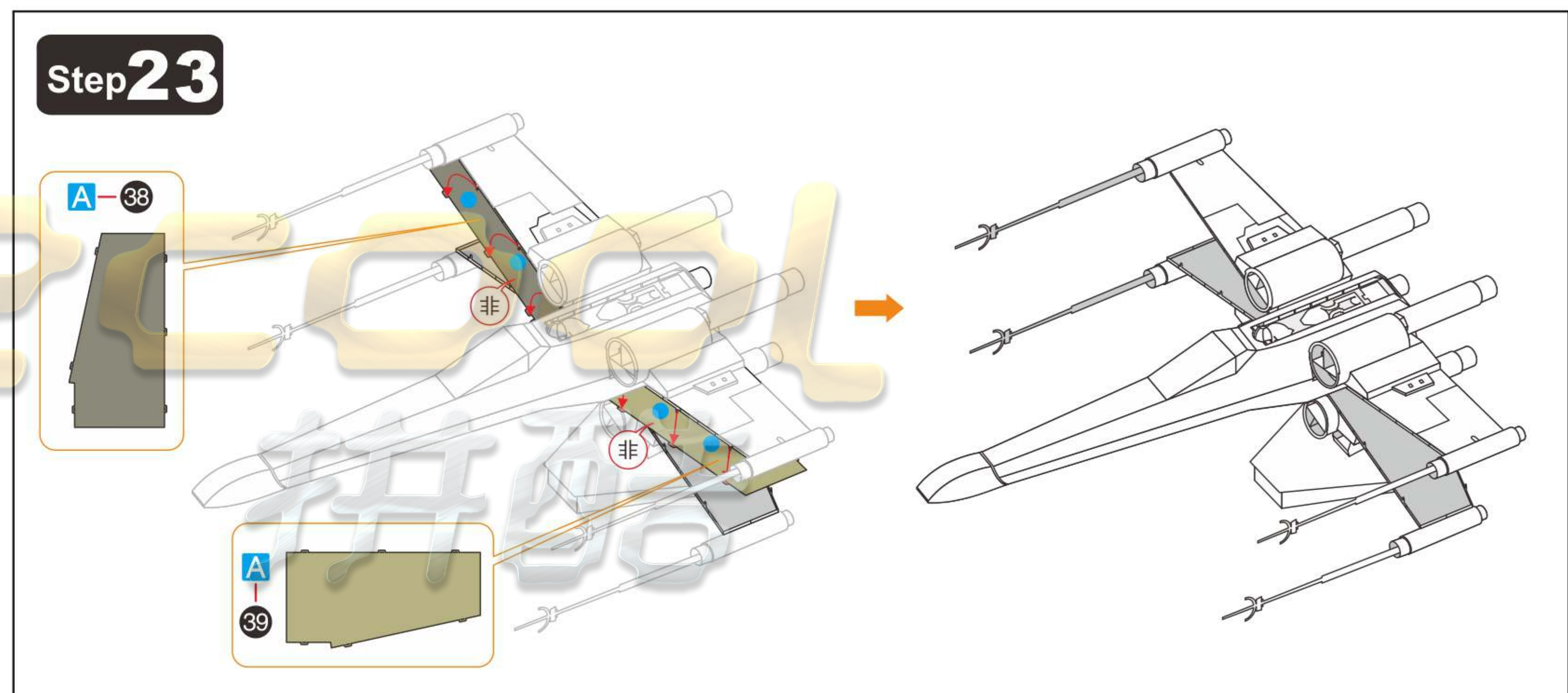
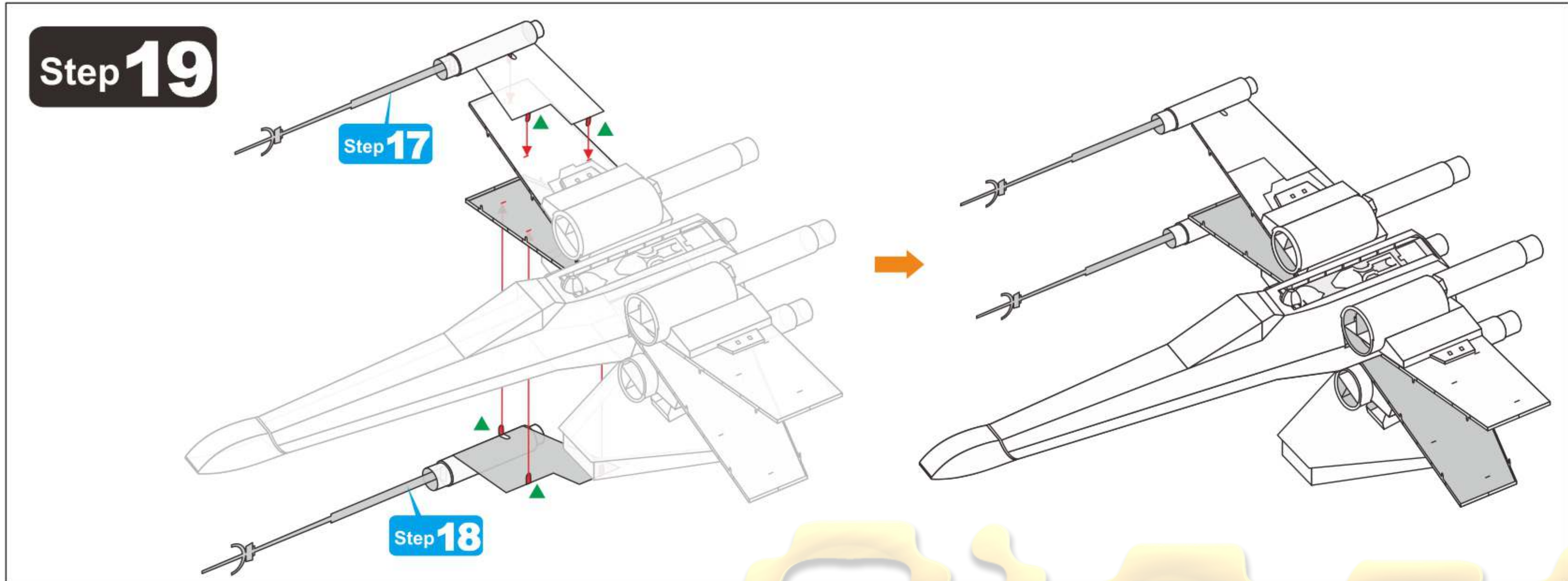
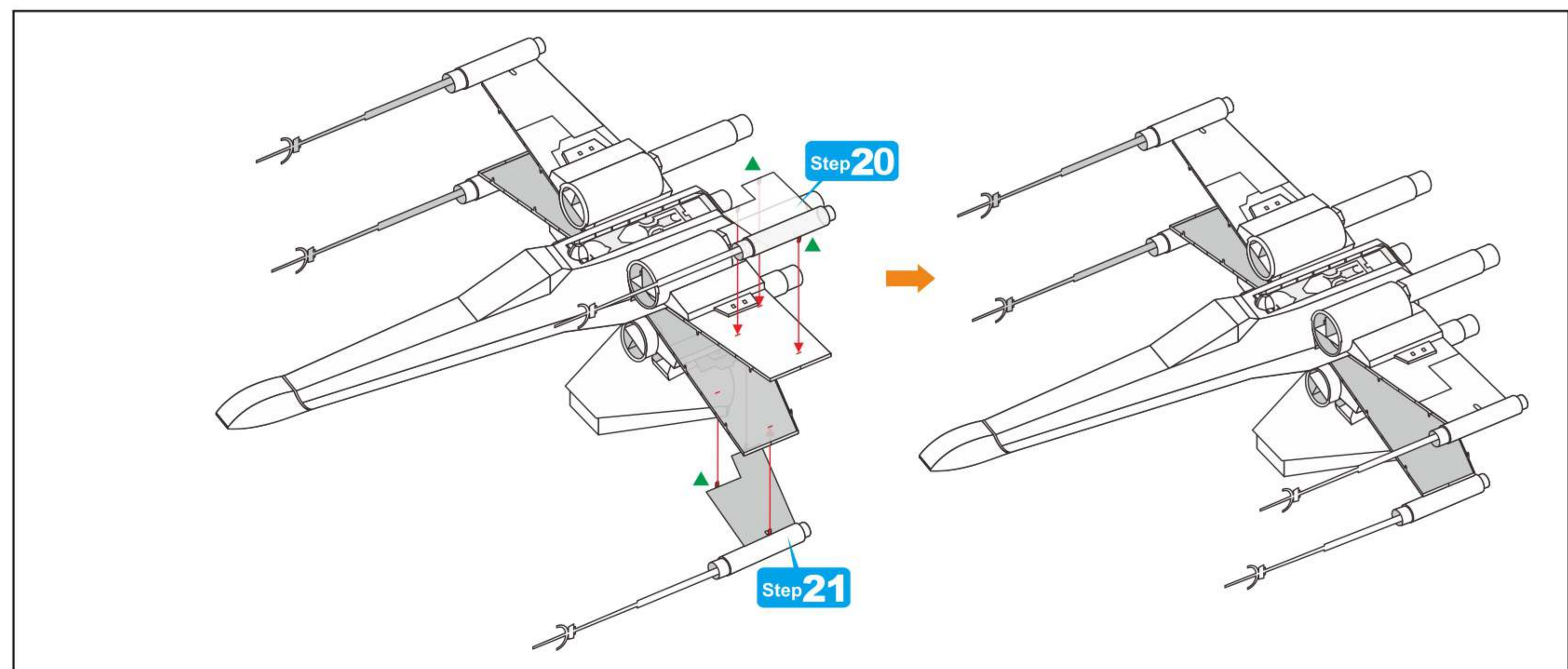
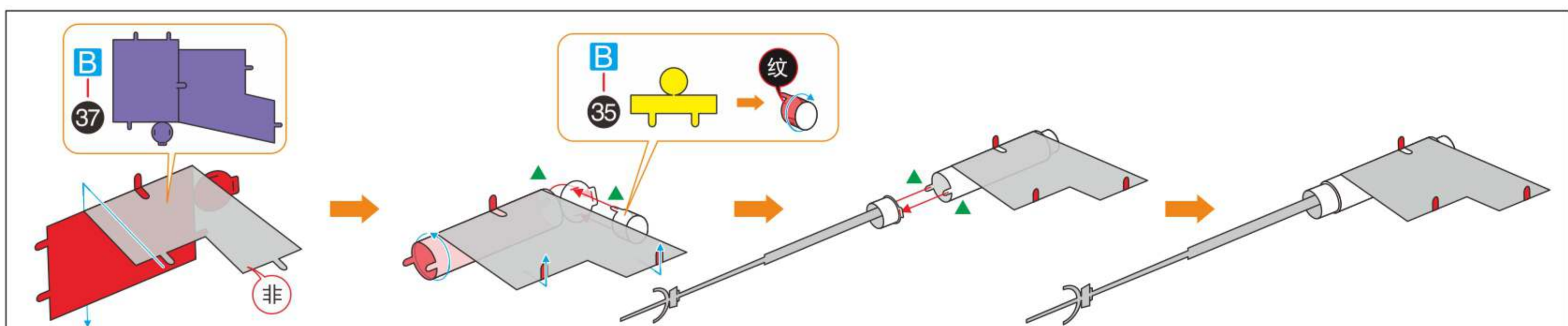
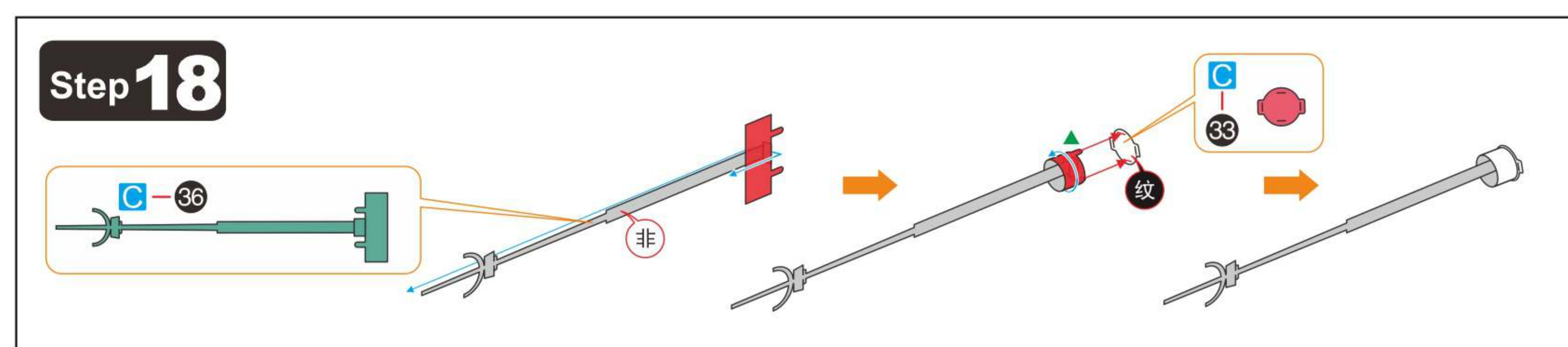
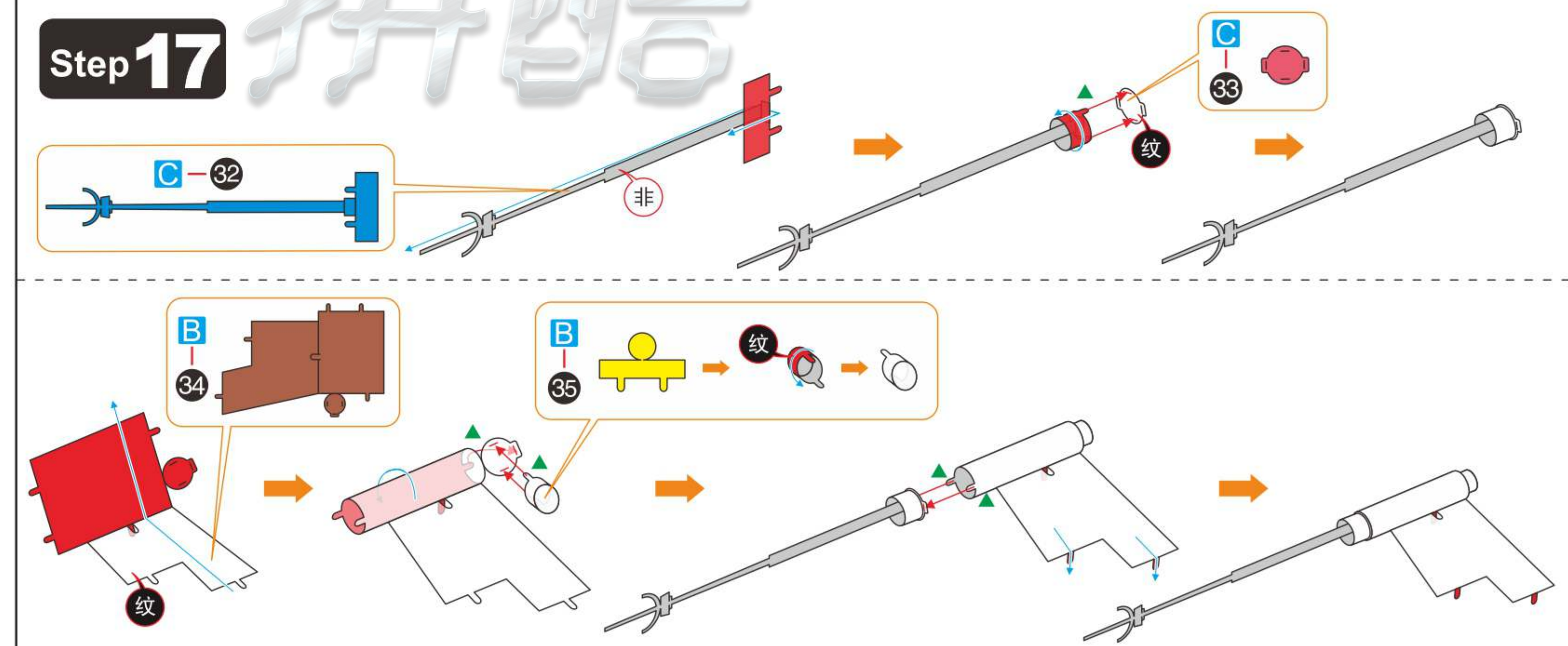
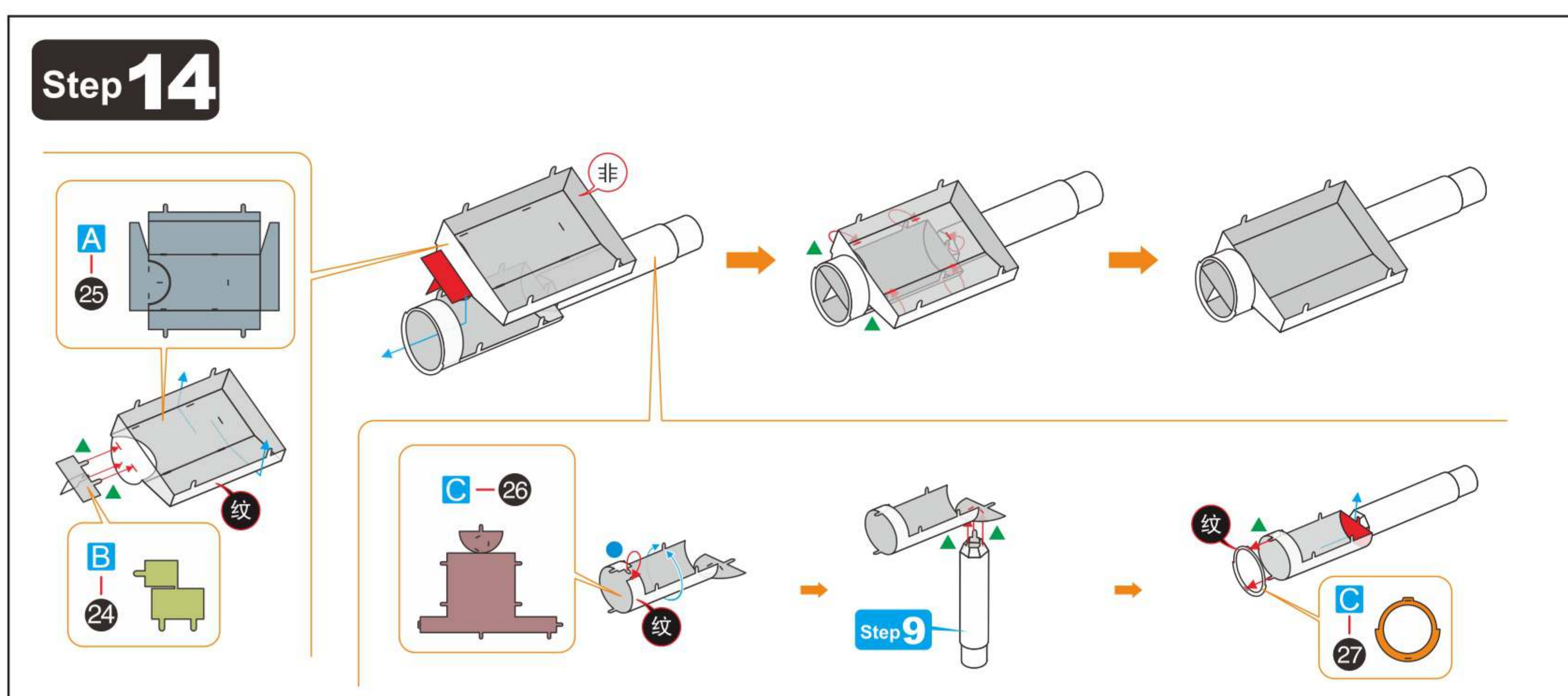
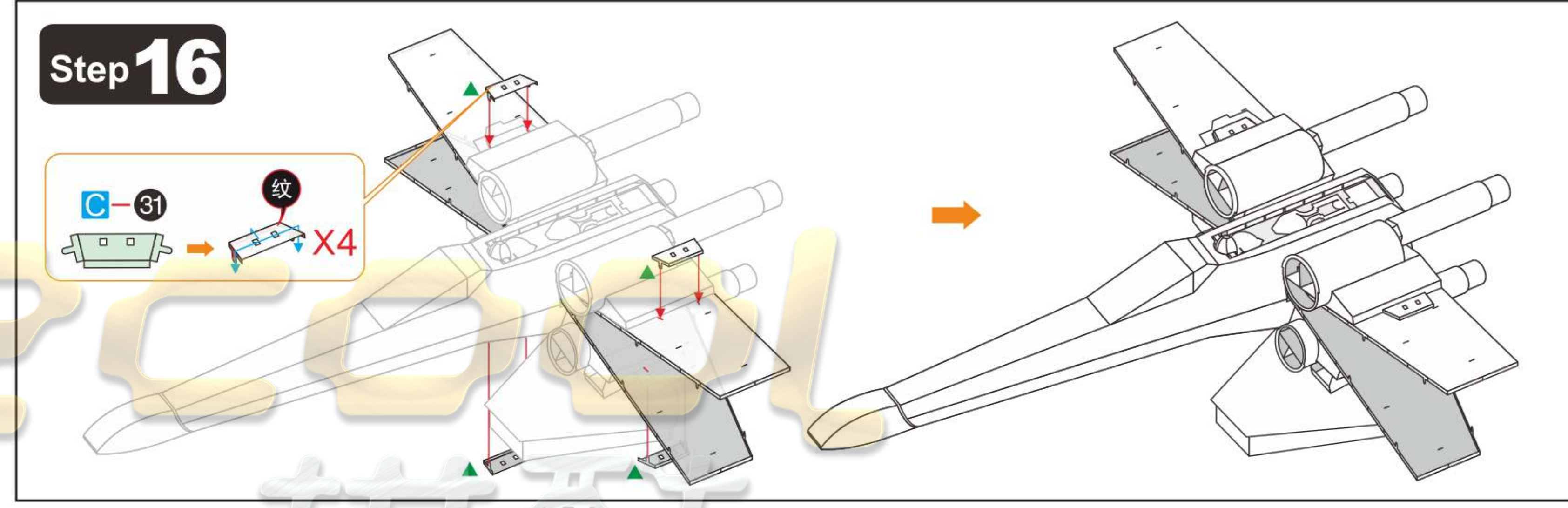
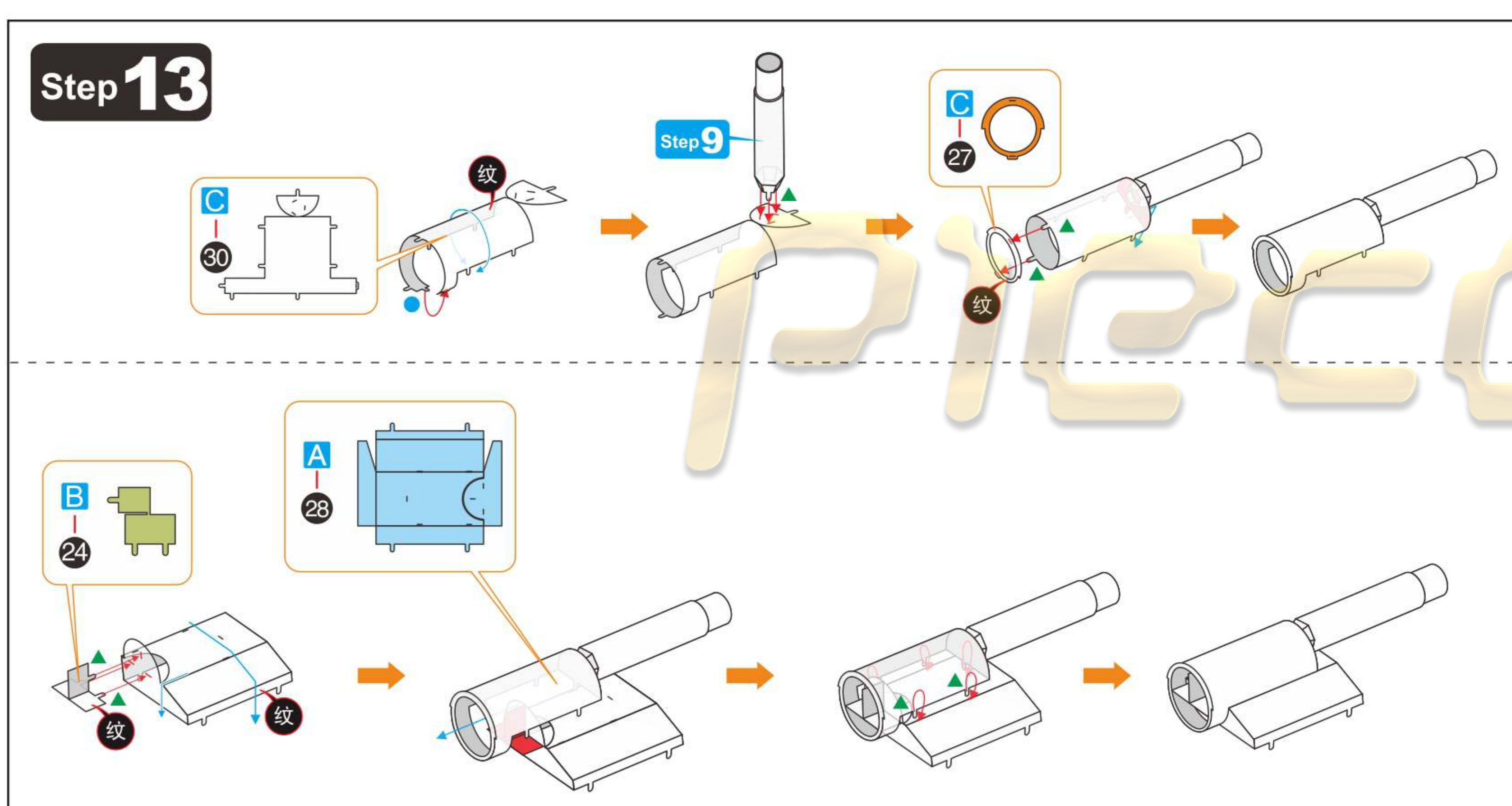
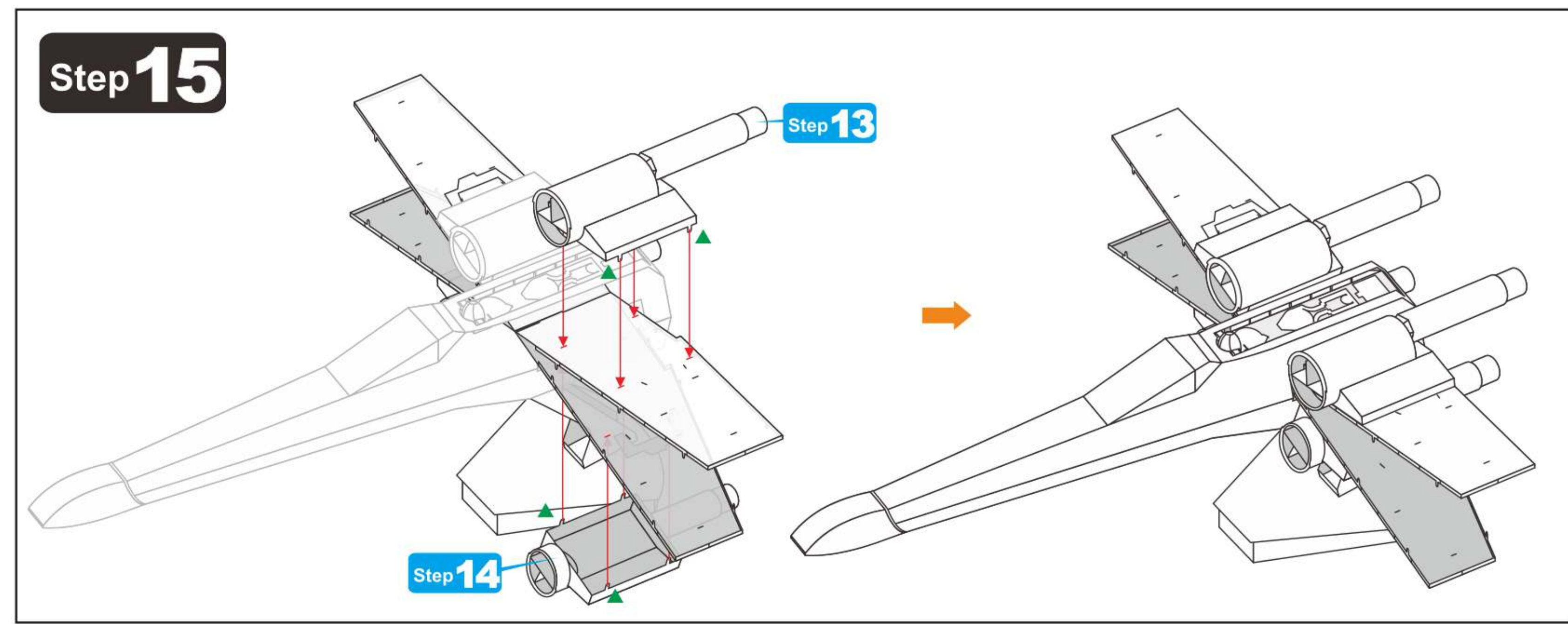
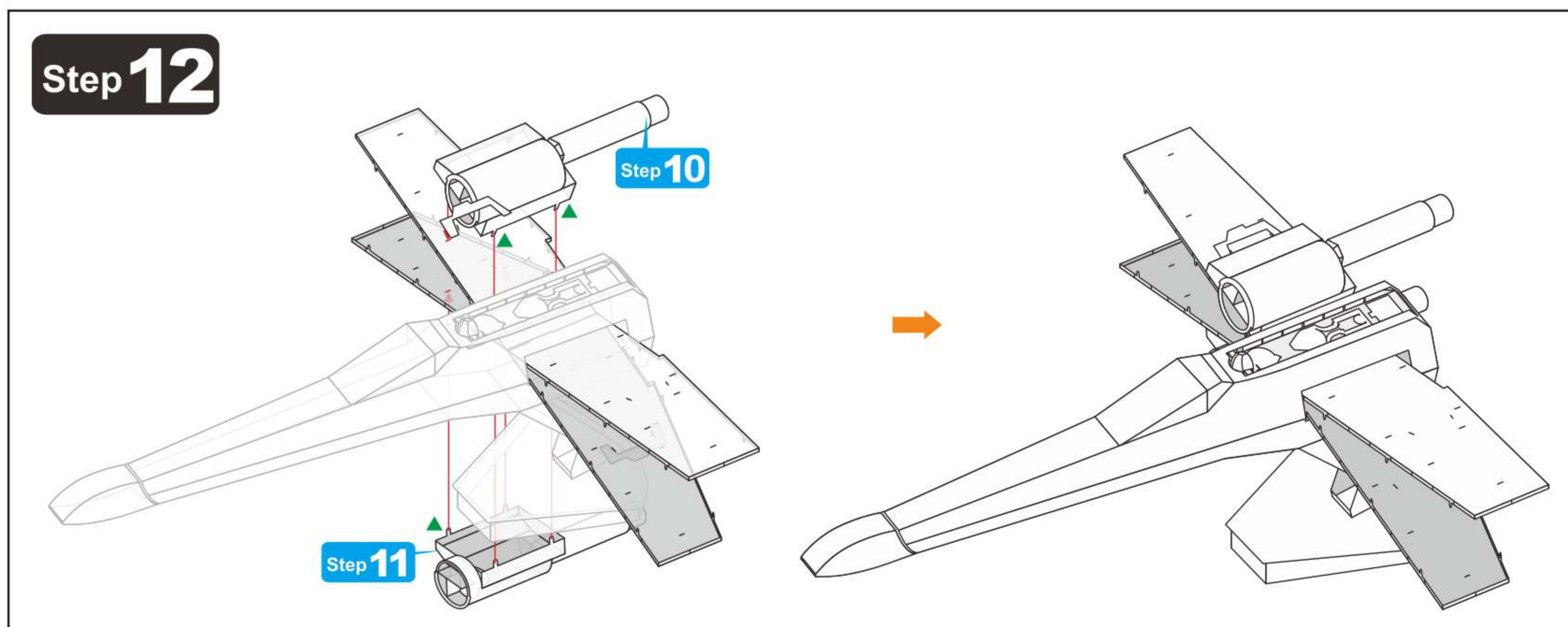



Piececool  
拼酷

[www.Piececool.com](http://www.Piececool.com)

© WIST PLASTIC & METAL TECHNOLOGY LIMITED. ALL RIGHTS RESERVED.