

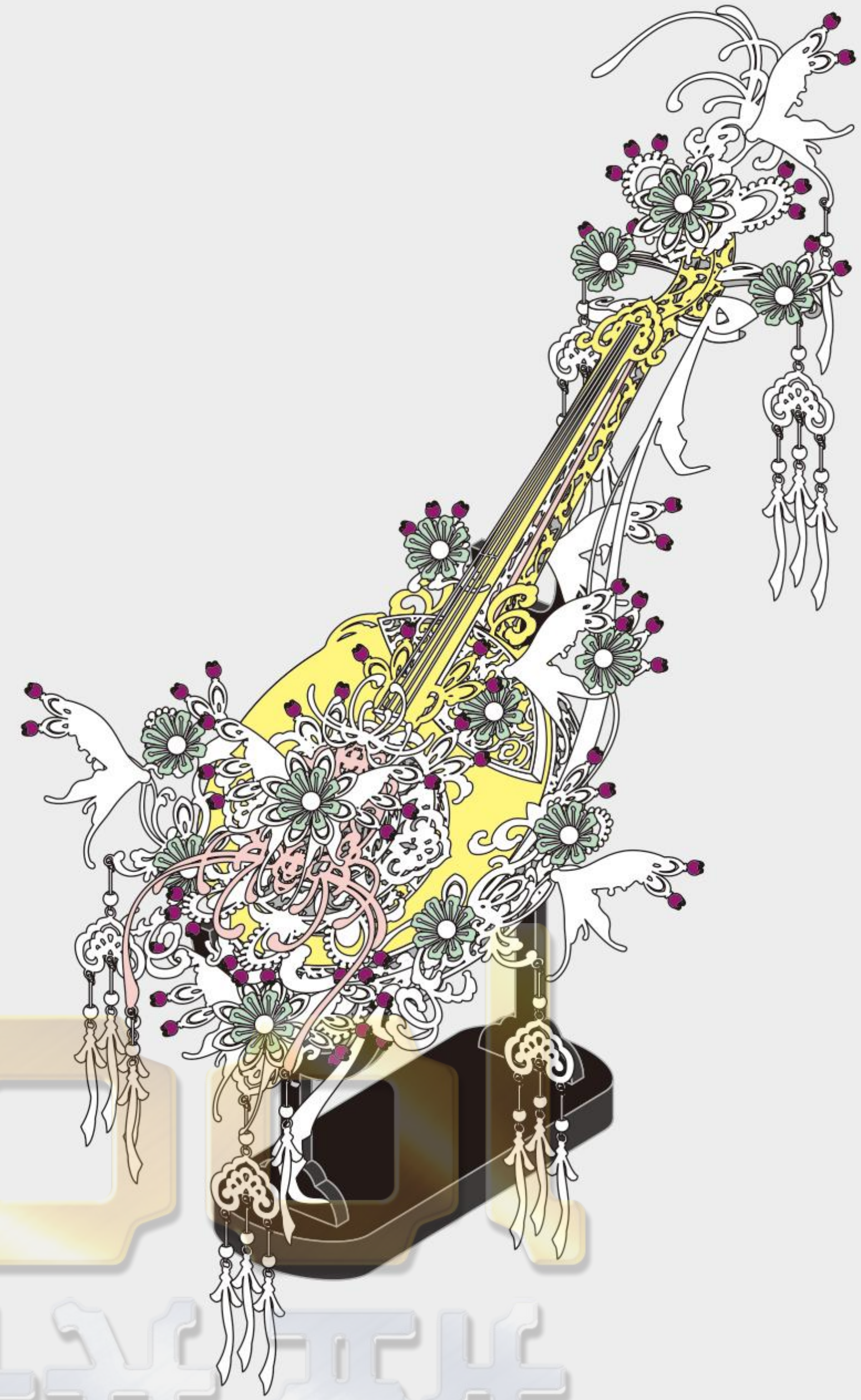

成品尺寸 Assembled model size
L14cm × W18cm × H17.5cm (含底座)



挑战星级 Difficulty Level



昭君出塞，
拨动阮弦，
奏起和平之曲。
所及之处，
福音回响。
她与她的阮曲，
可使大雁沉落，
也为古今所称颂。

商品信息：

产品名称：昭君阮
产品型号：P343
产品材质：430不锈钢
成品尺寸：L14cm × W18cm × H17.5cm
适用年龄：14岁以上

电子版下载：



<http://www.piececool.com/cpshuoming/P343.pdf>

内含金属片：

金属片数：11cm × 21cm × 2⁵/₈ (Pcs)+101配件



补件流程：



进入拼酷公众号/官网



选择【零件补给】程序



根据商品编号/类别/年份
查找对应商品



填写零件补给表单



支付邮费



等待收件

*零件补给服务具体条款、服务范围、邮费标准，请参考【零件补给】程序的服务说明，
服务最终解释权归微石所有。



组装时请小心处理金属零件，以防划伤！

Please handle metal sheets with care,
The parts may have sharp edges that
could cut or scratch skin.
Keep away from Children.

(1) 准备工具：

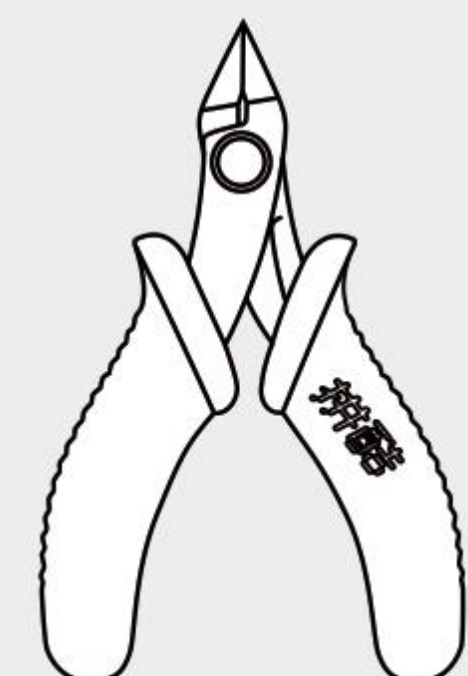

水口钳工具

修剪金属片板件
上的零件水口位

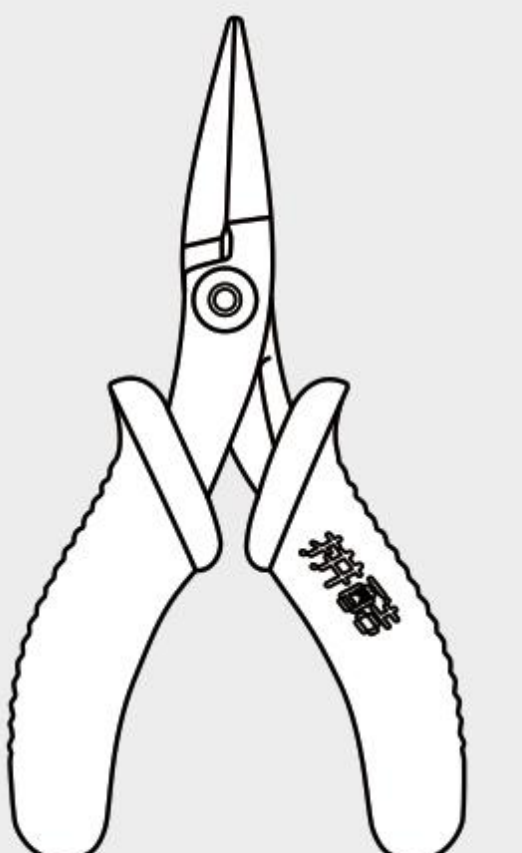

尖嘴钳工具

弯折金属零件上的
折叠线和扣点

*建议使用拼酷正品拼装工具(水口钳、尖嘴钳)
拼装时更省心、省力,拼装后作品更精细、美观!

(2) 取下零件：



使用水口钳剪断金属零件上的水口，
将需要的金属零件从金属片板件取下。

(3) 识别零件：

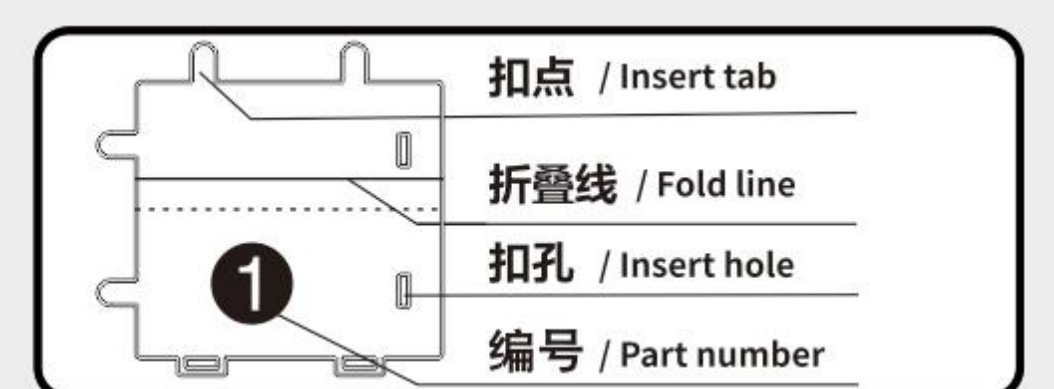

零件编号在金属片板件背面
识别金属零件上的扣点、折叠线、扣孔的样子。

(4) 折叠零件：

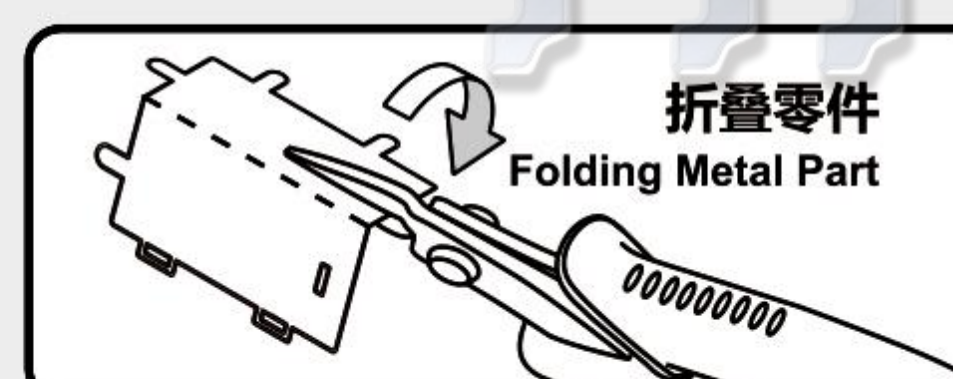

使用尖嘴钳,参照拼装说明书将金属零件折成形状。

(5) 固定零件：



扣点插入扣孔,旋转90°固定零件,再平折。

(6) 注意事项：

- 颜色面
- 纹理面
- 非颜色面
- 非纹理面
- 零件正面
- 零件背面
- 或编号面
- 注意细节
- 注意片对称
- 注意颜色和纹理不在同一个面时

剪金属零件时请剪零件“水口位”，请勿将“扣点”当成“水口位”剪下，每次剪零件时请仅剪当前步骤的零件，切勿一次性将所有零件全部剪下，避免丢失；

当遇到折叠线的零件,请注意金属片的正反面及拼折方向,请按照说明书的方向,轻剪慢折,最好一次性折叠完成,请勿反复折叠,避免零件损坏。

拼装步骤:

Step 01

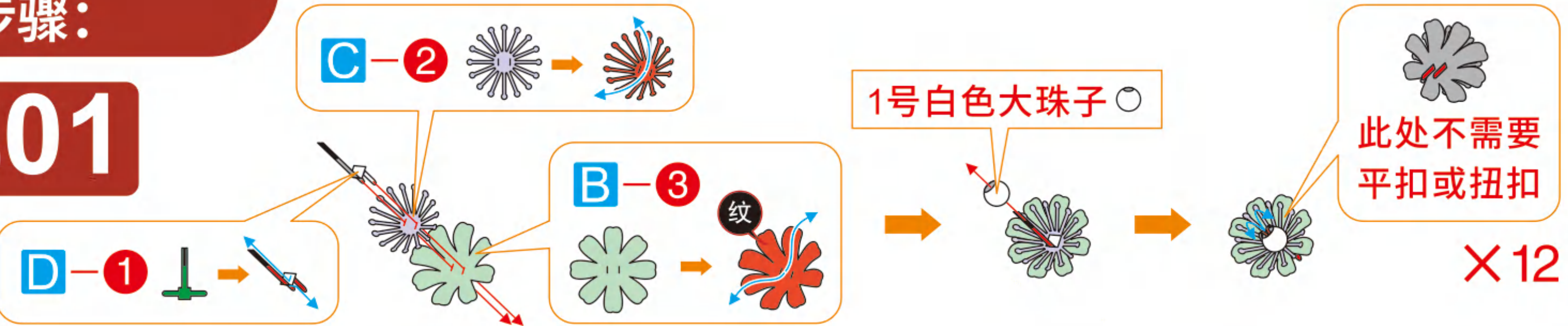

Step 02



Step 03

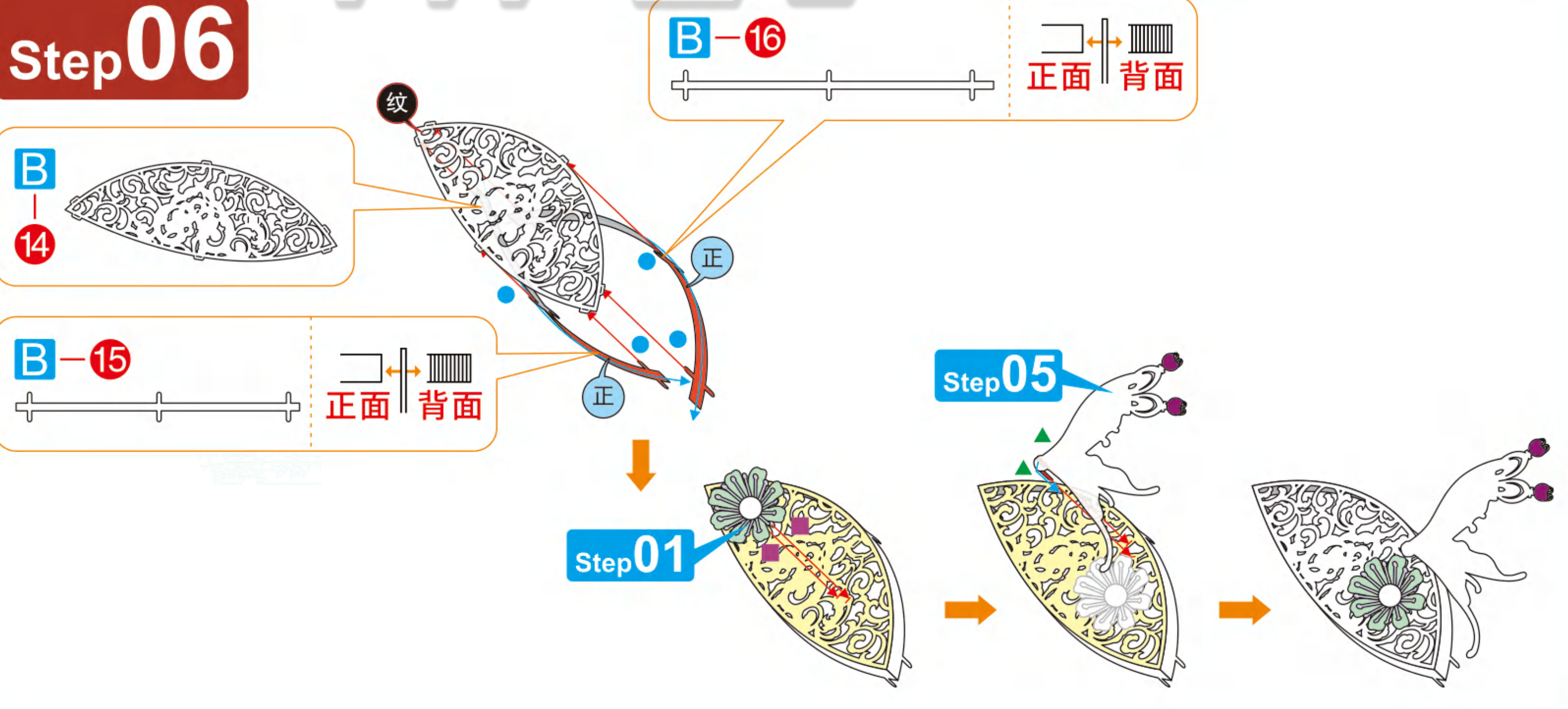
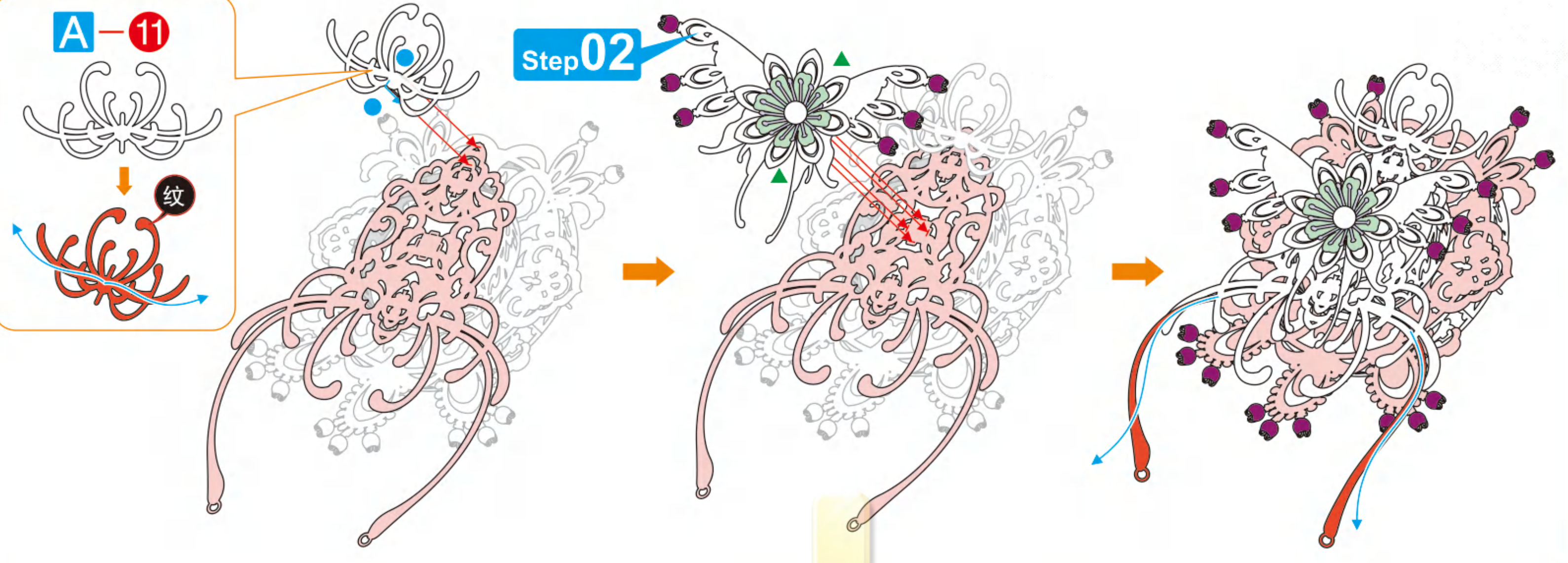
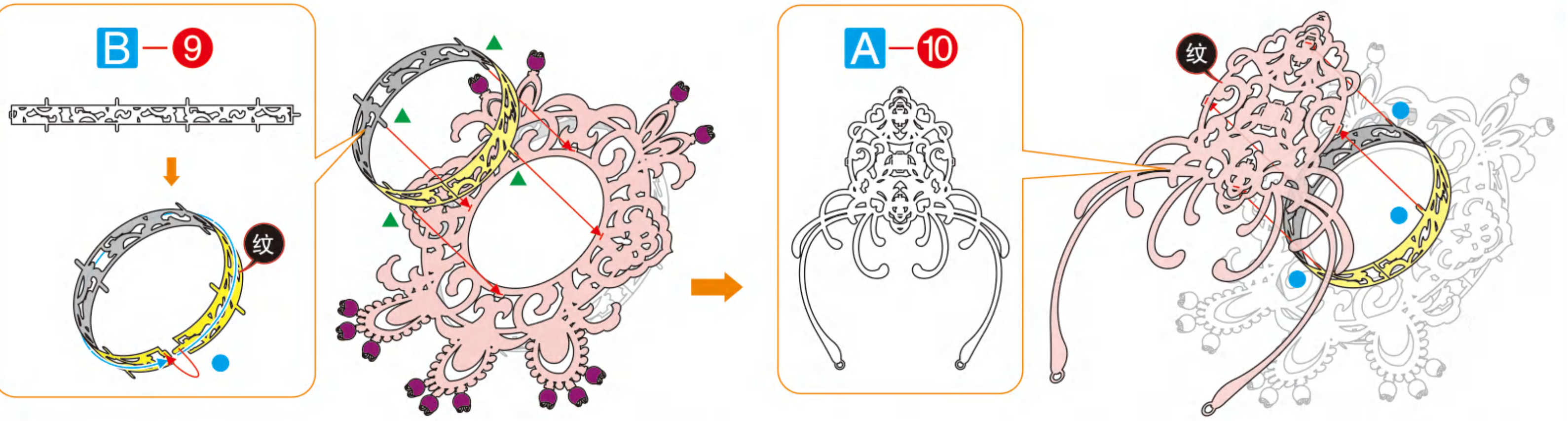
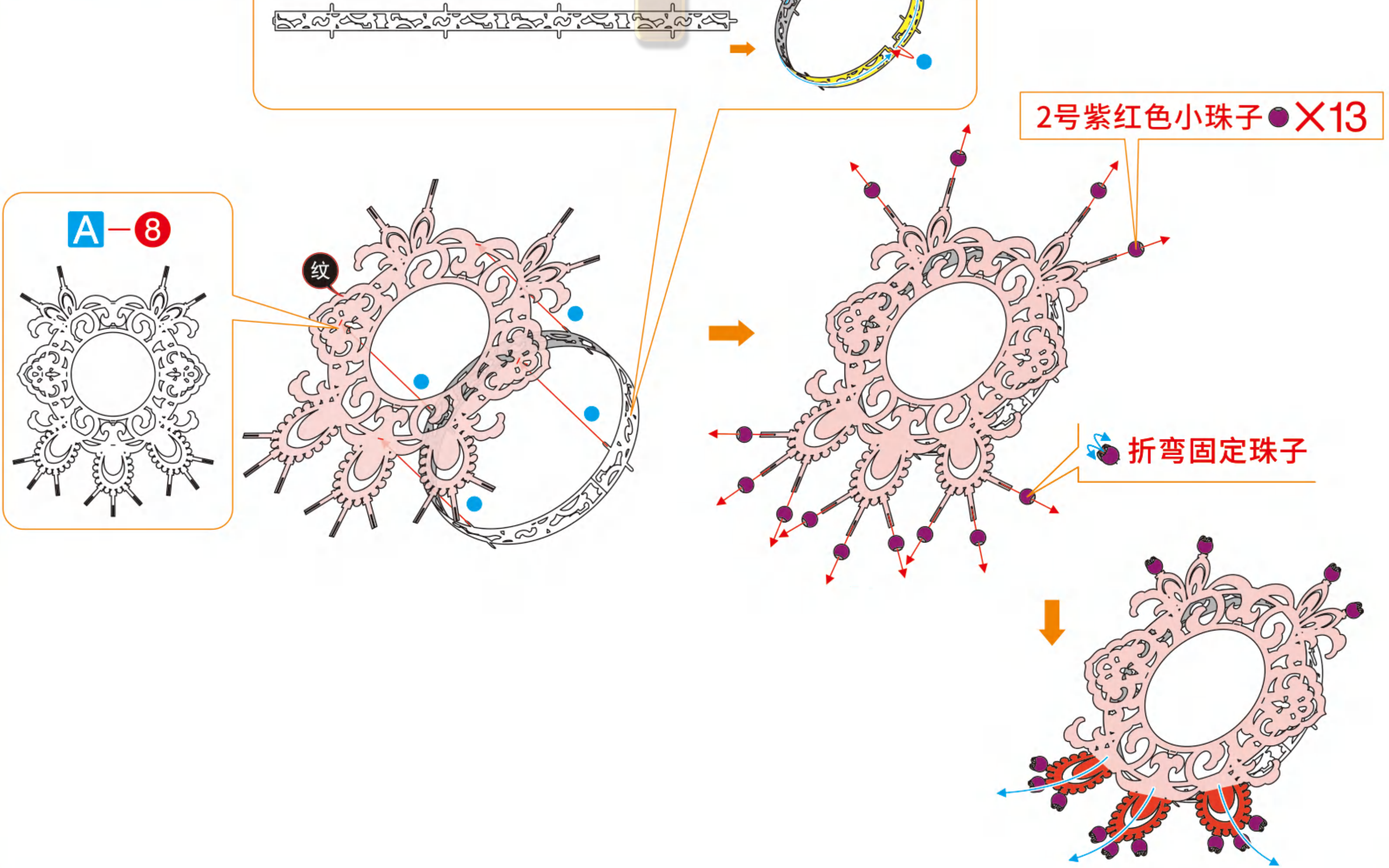

Step 07

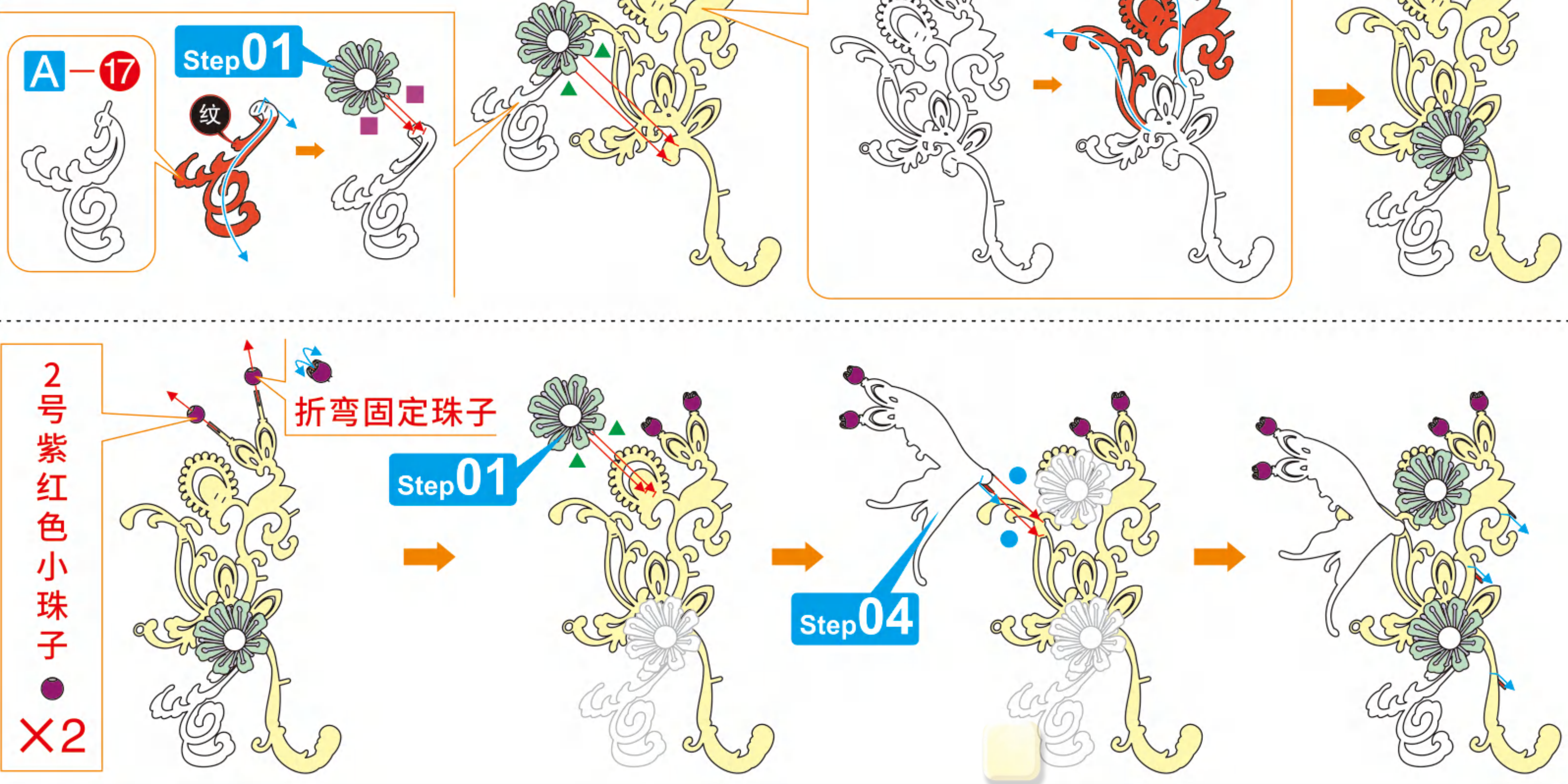

Step 08

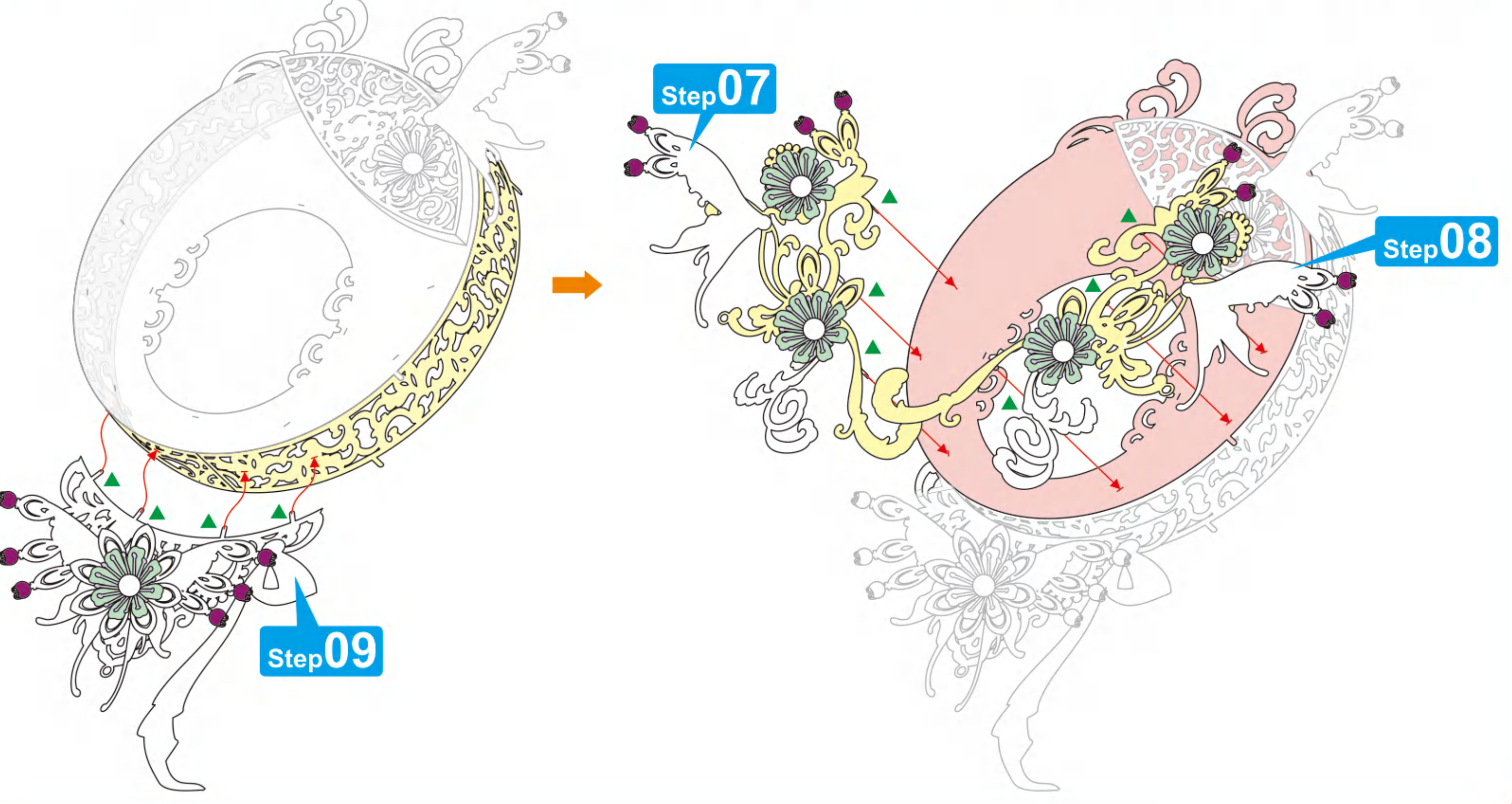
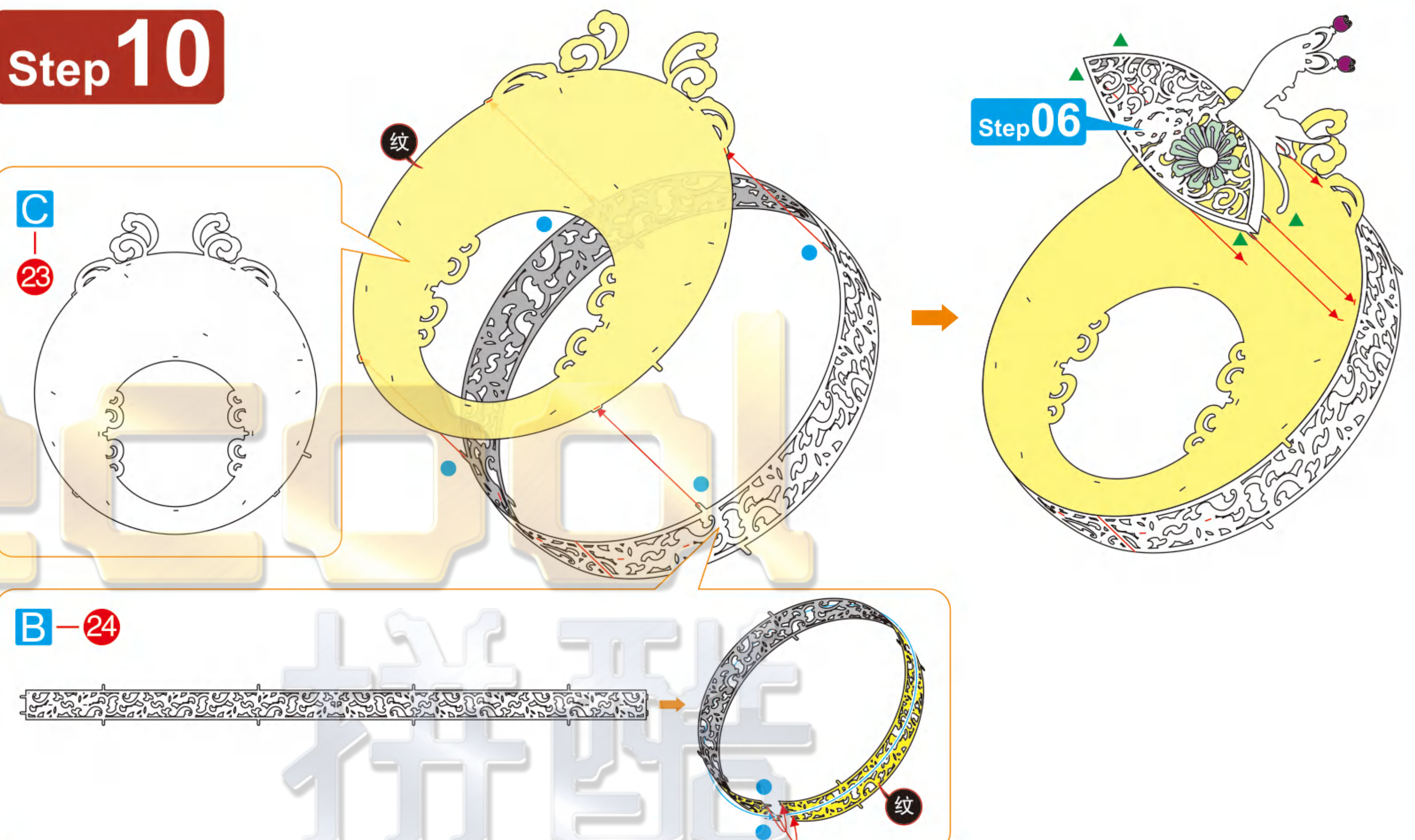
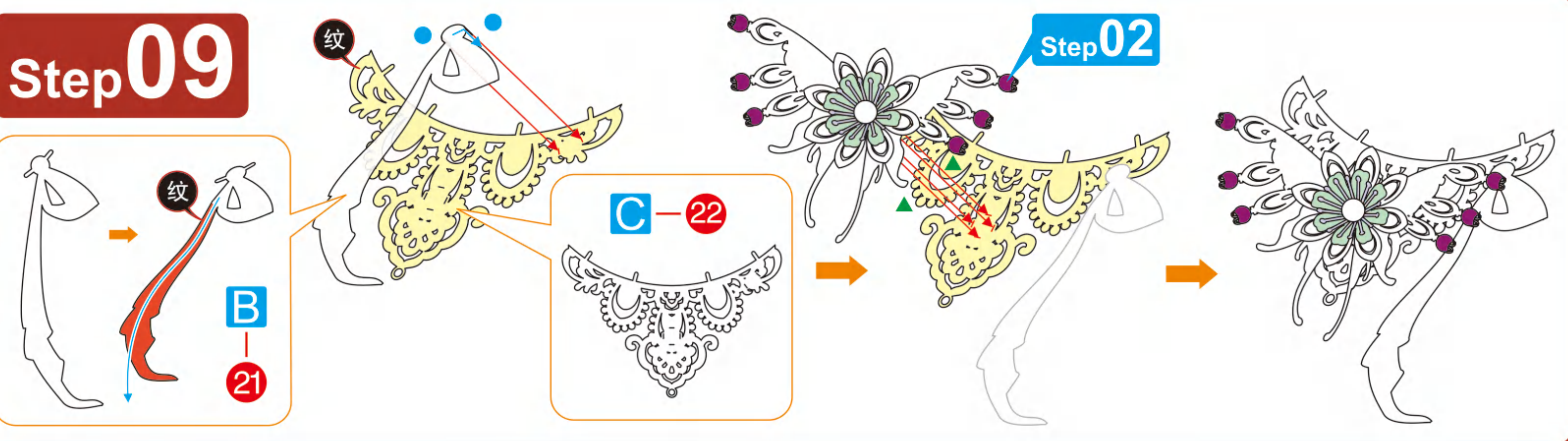
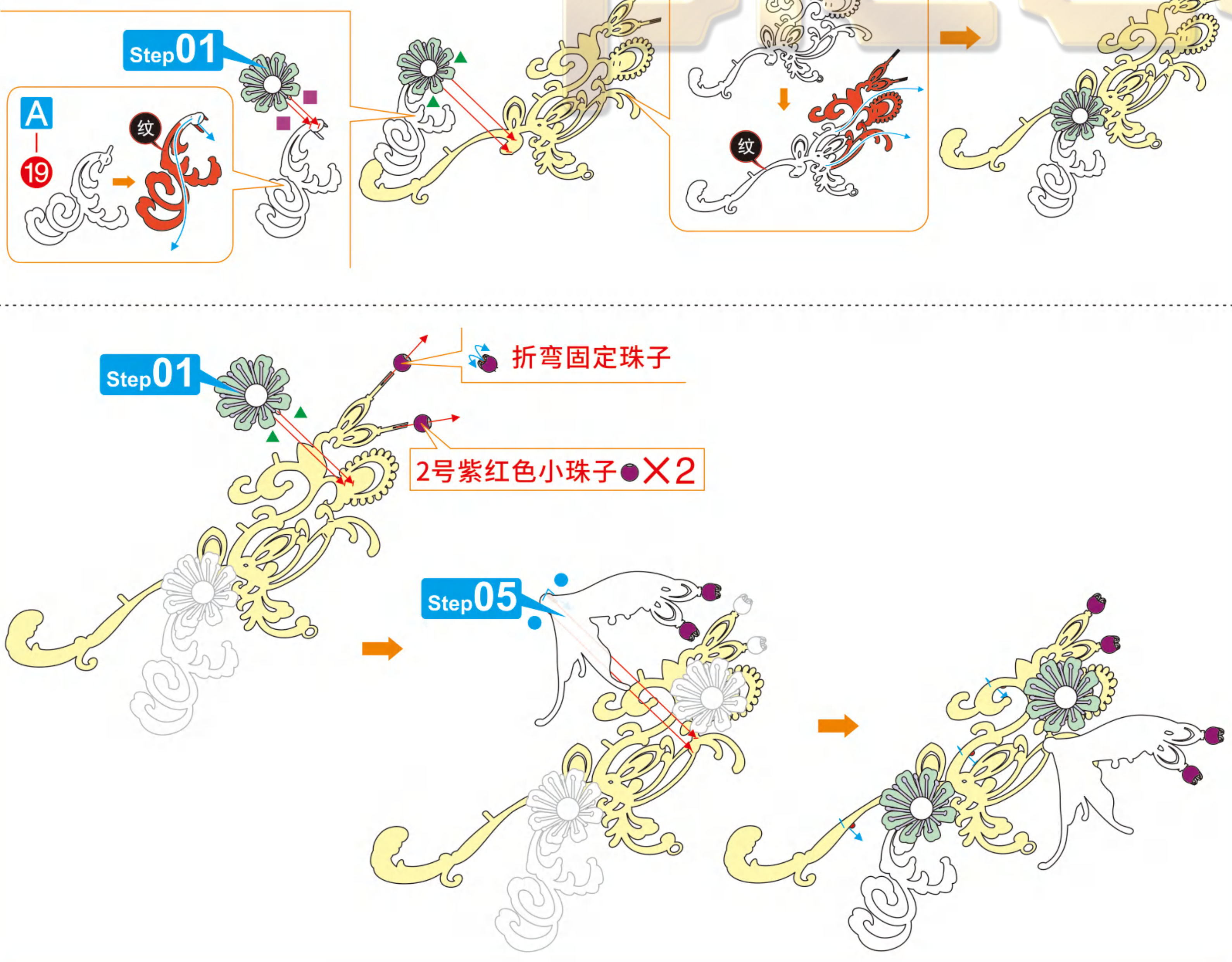

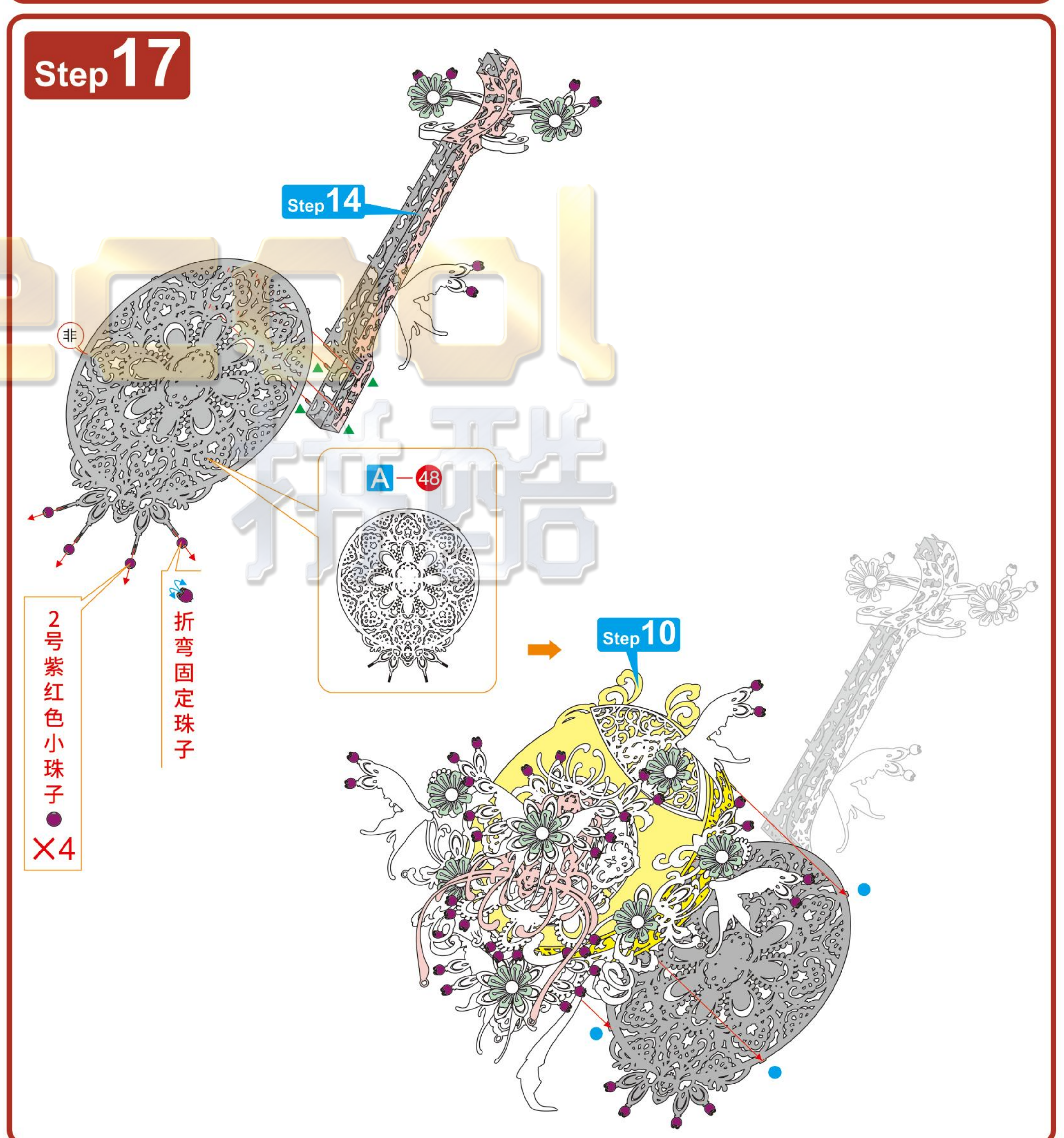
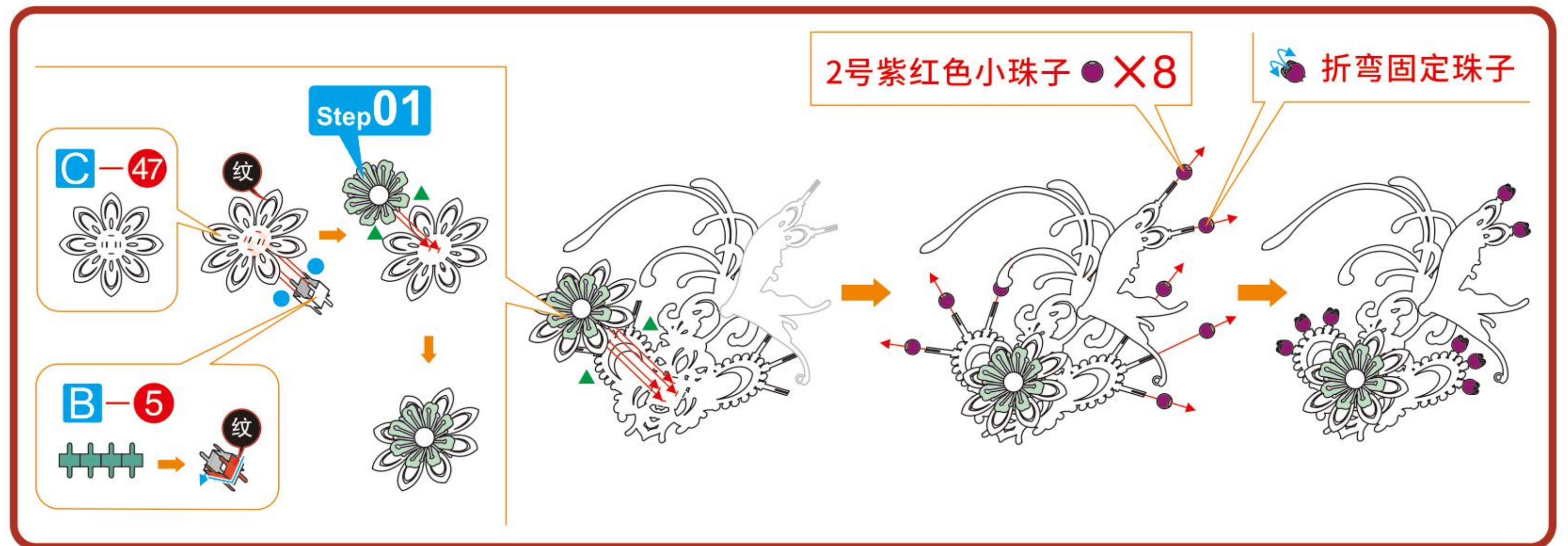
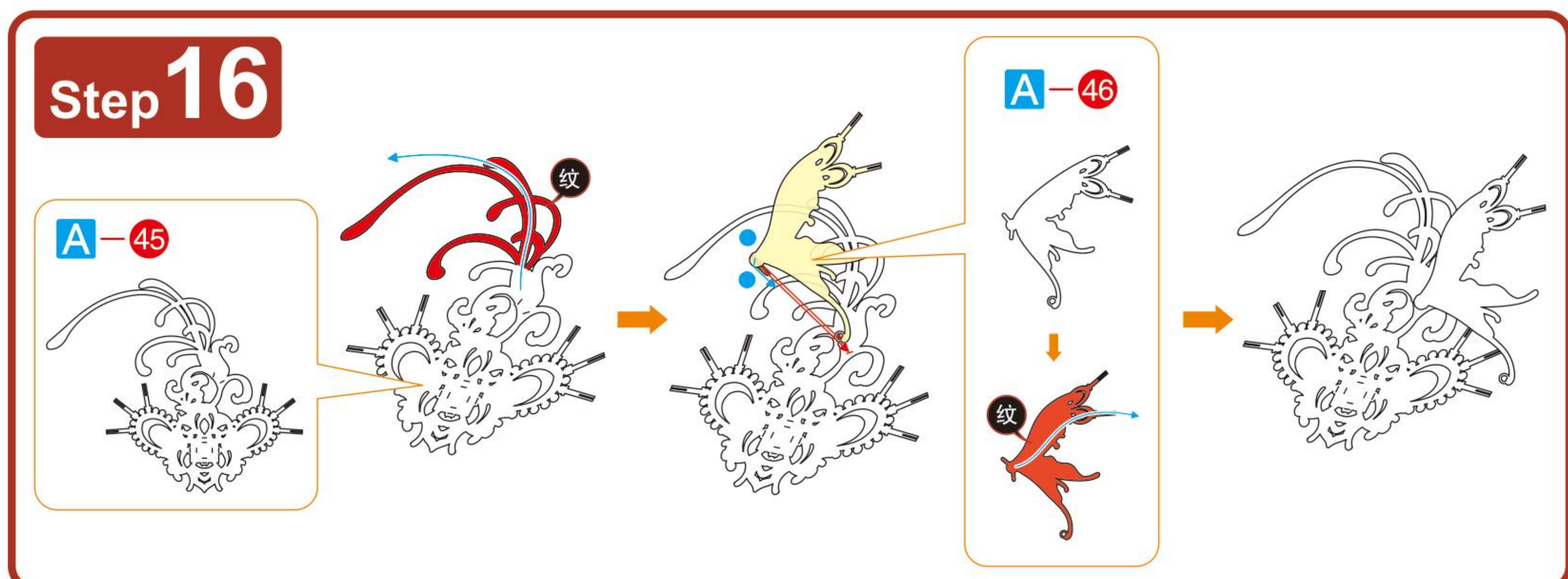
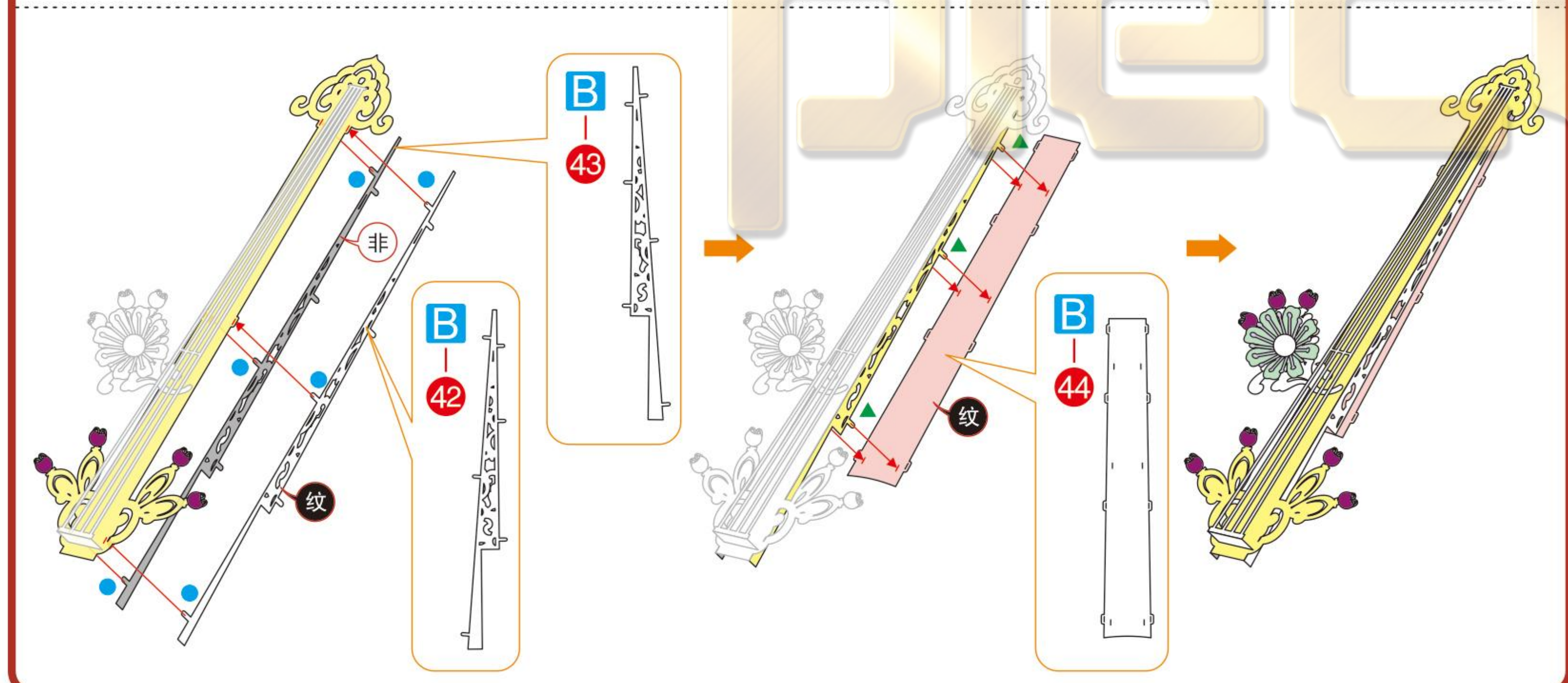
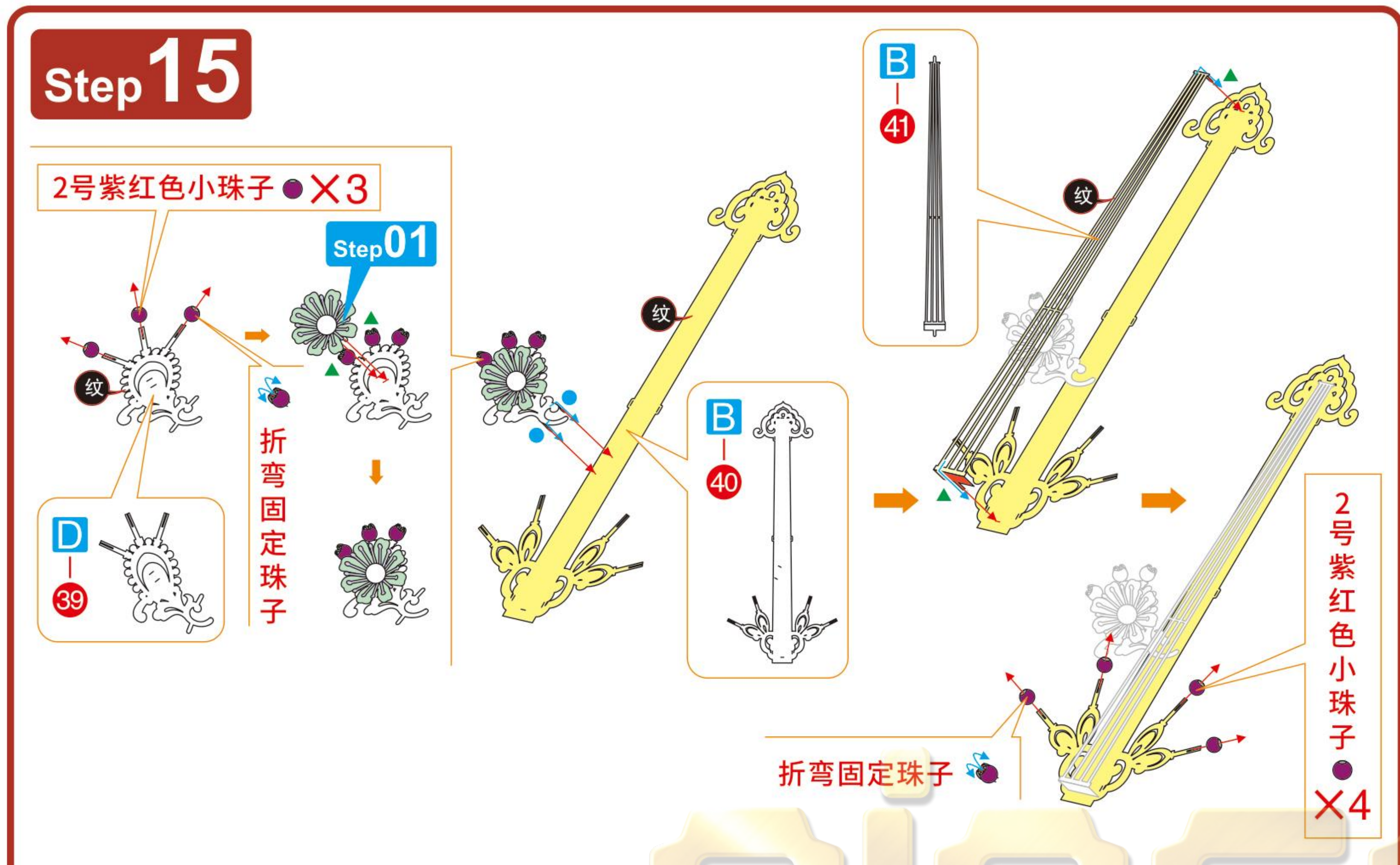
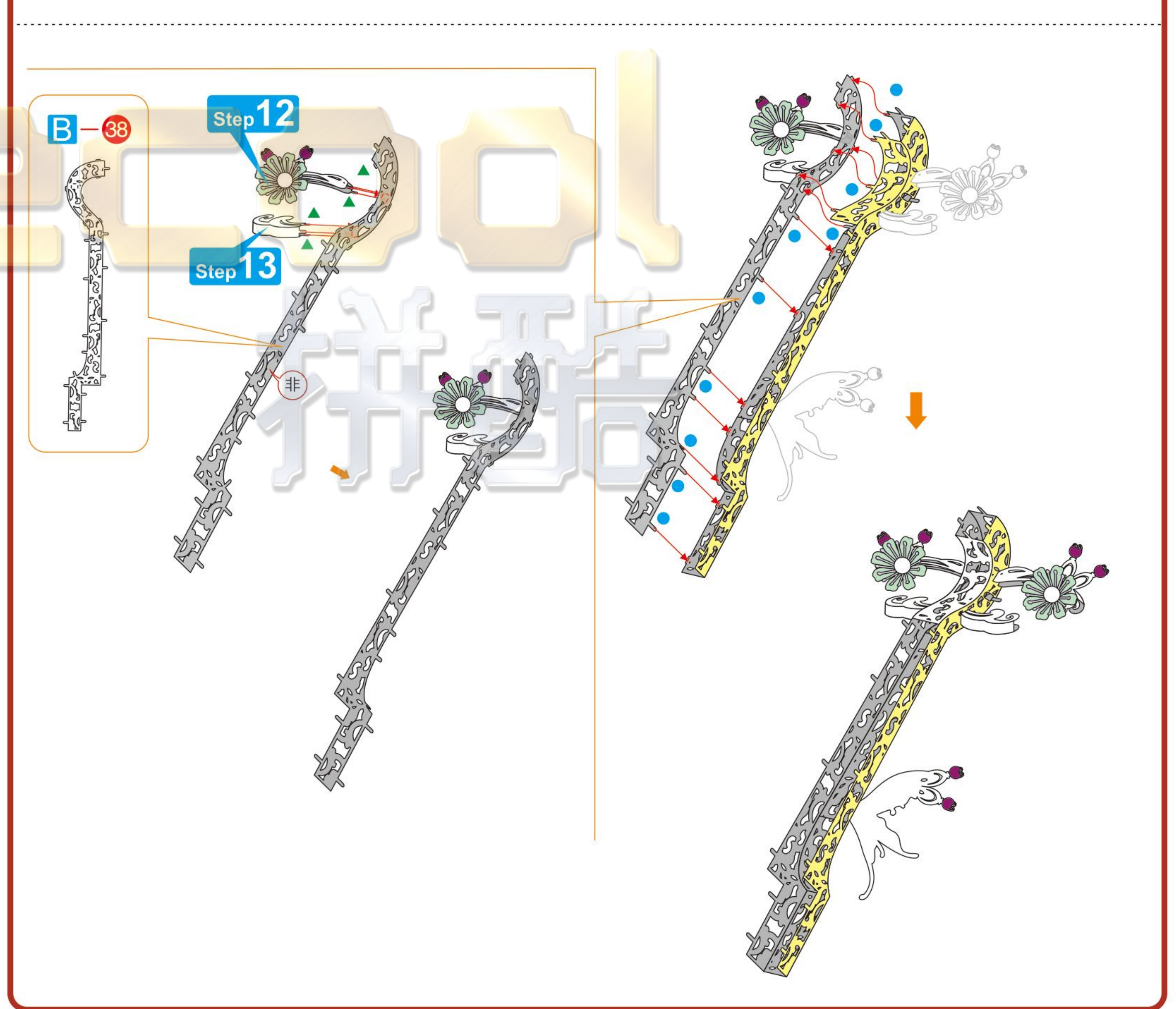
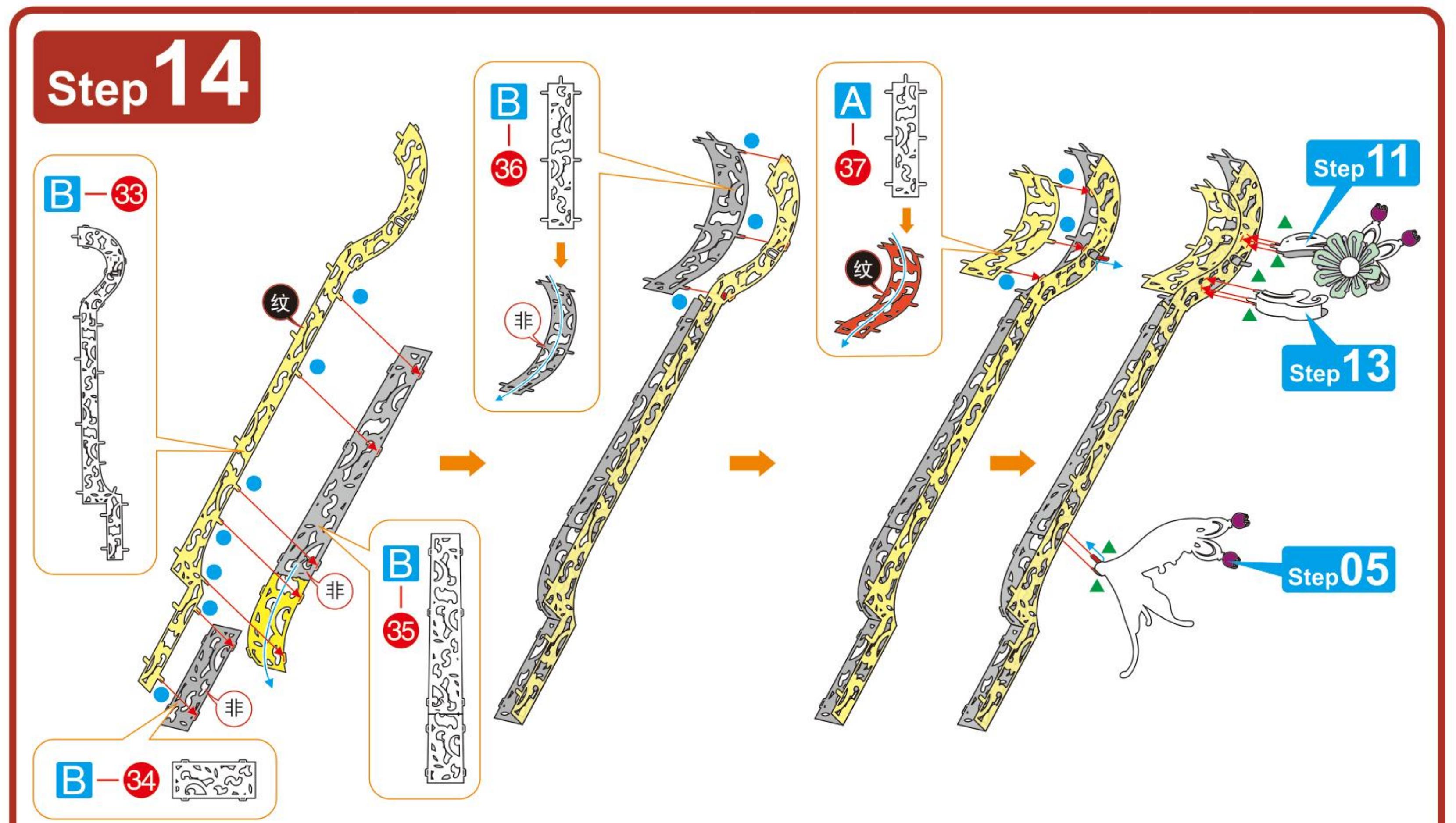
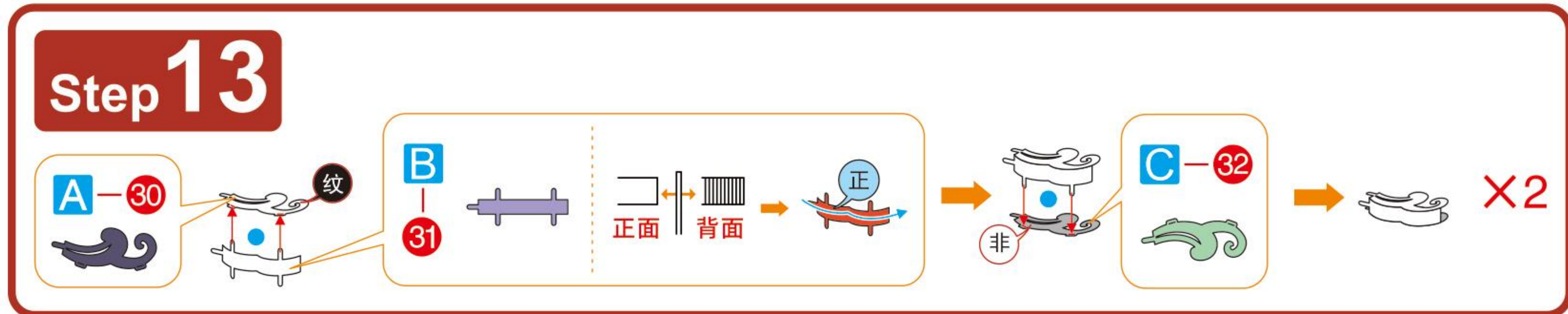
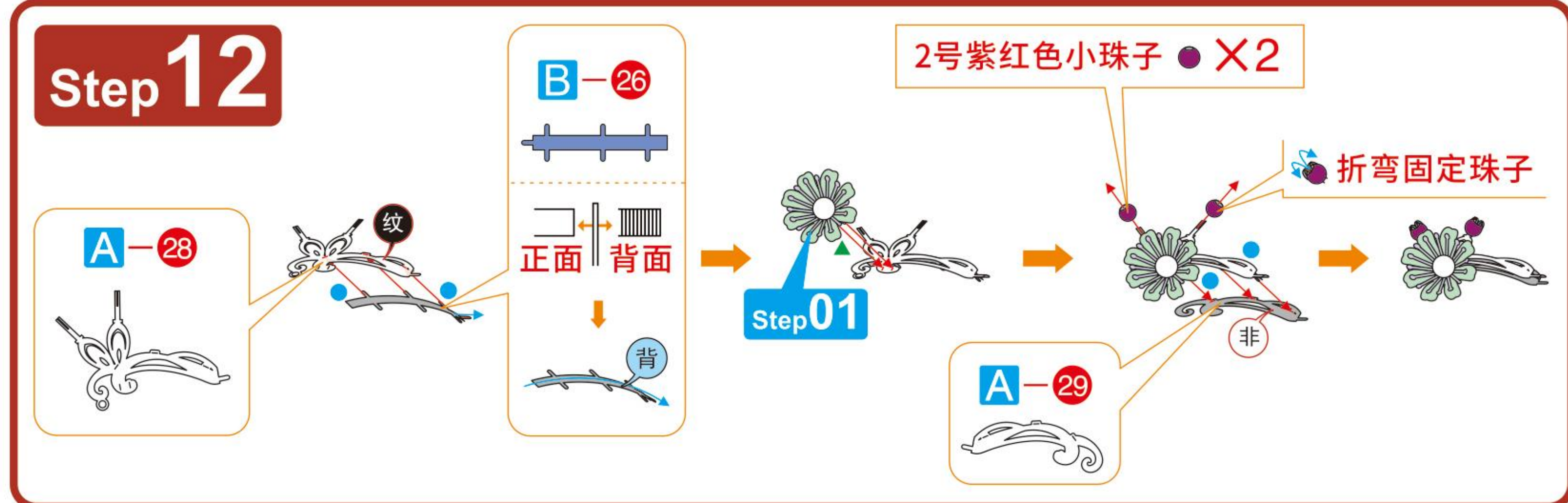
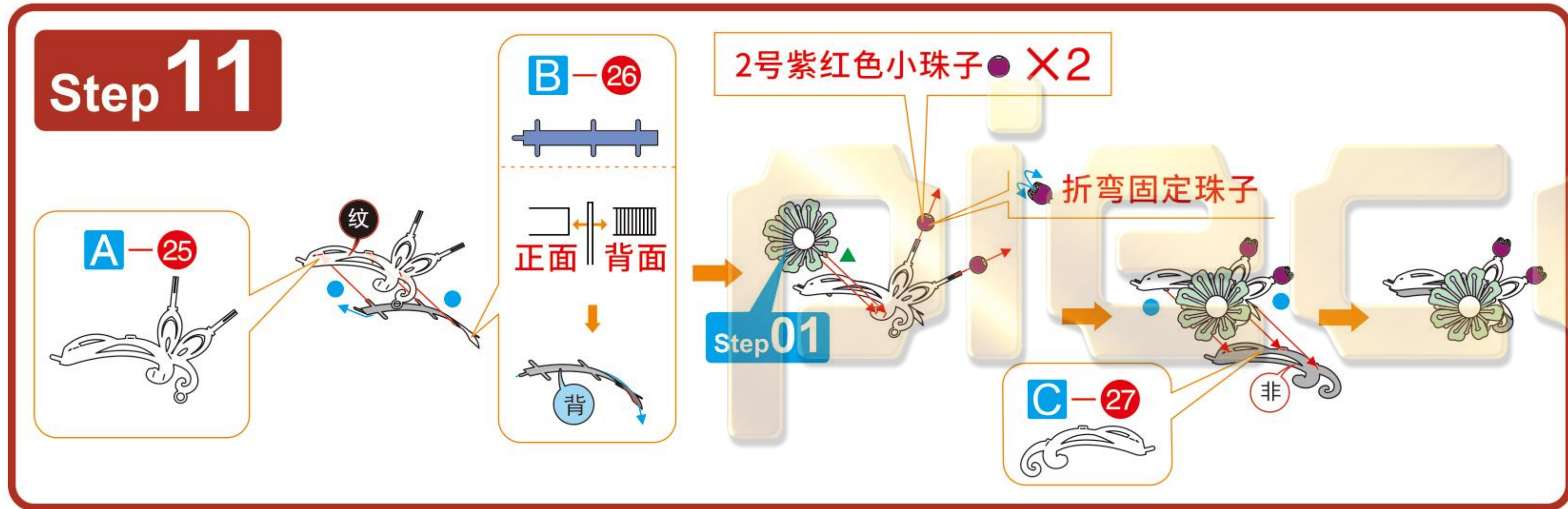
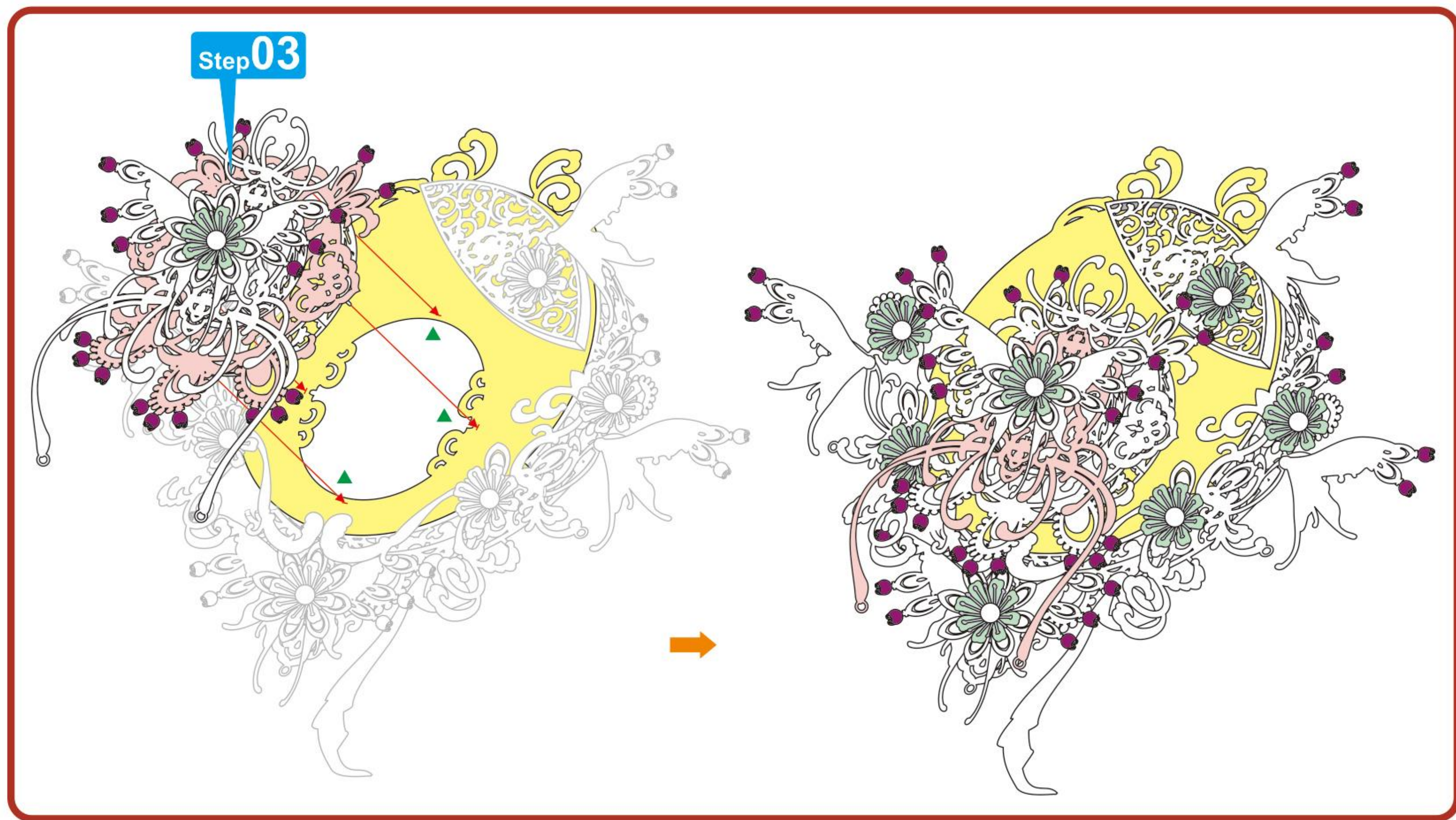

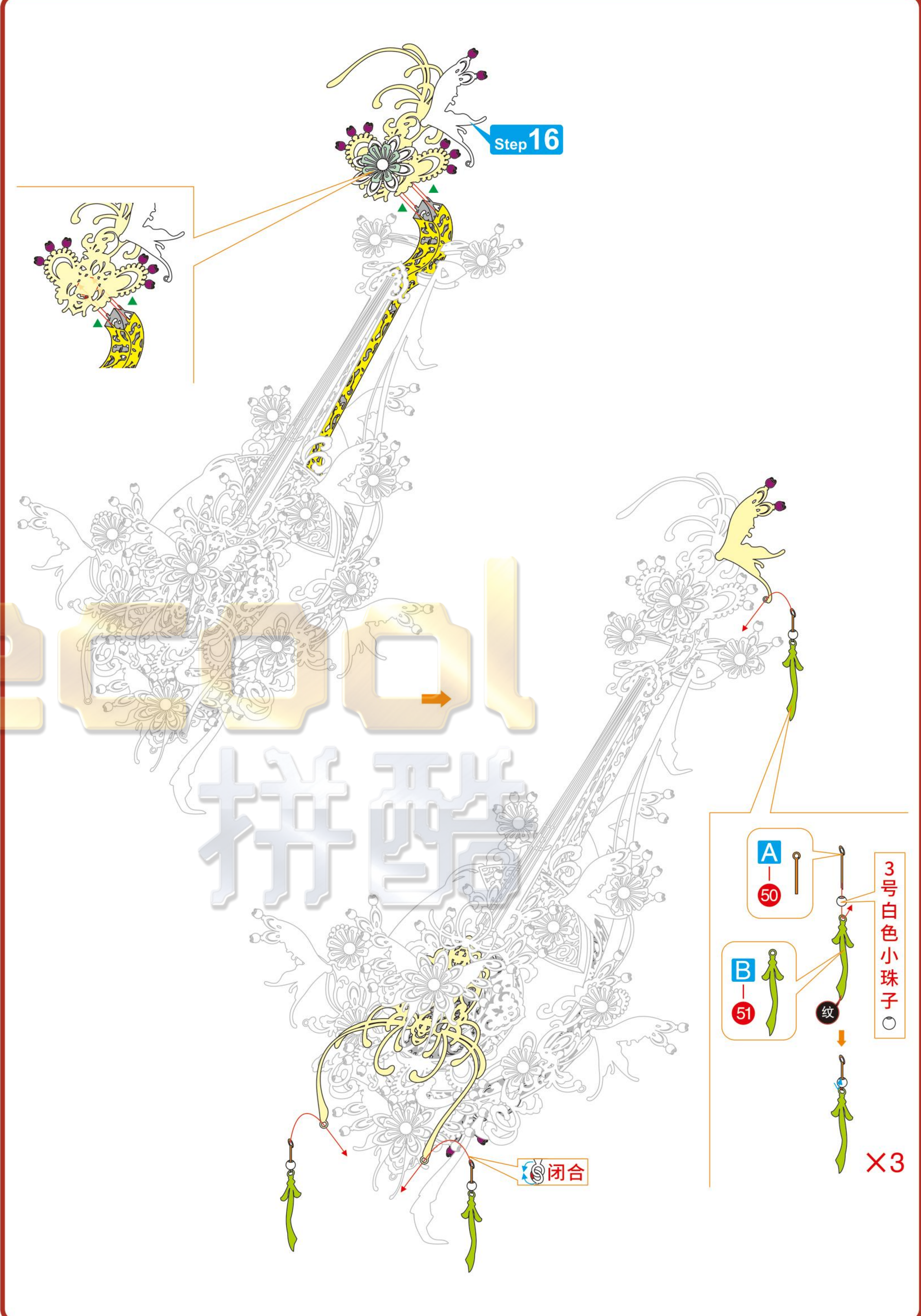
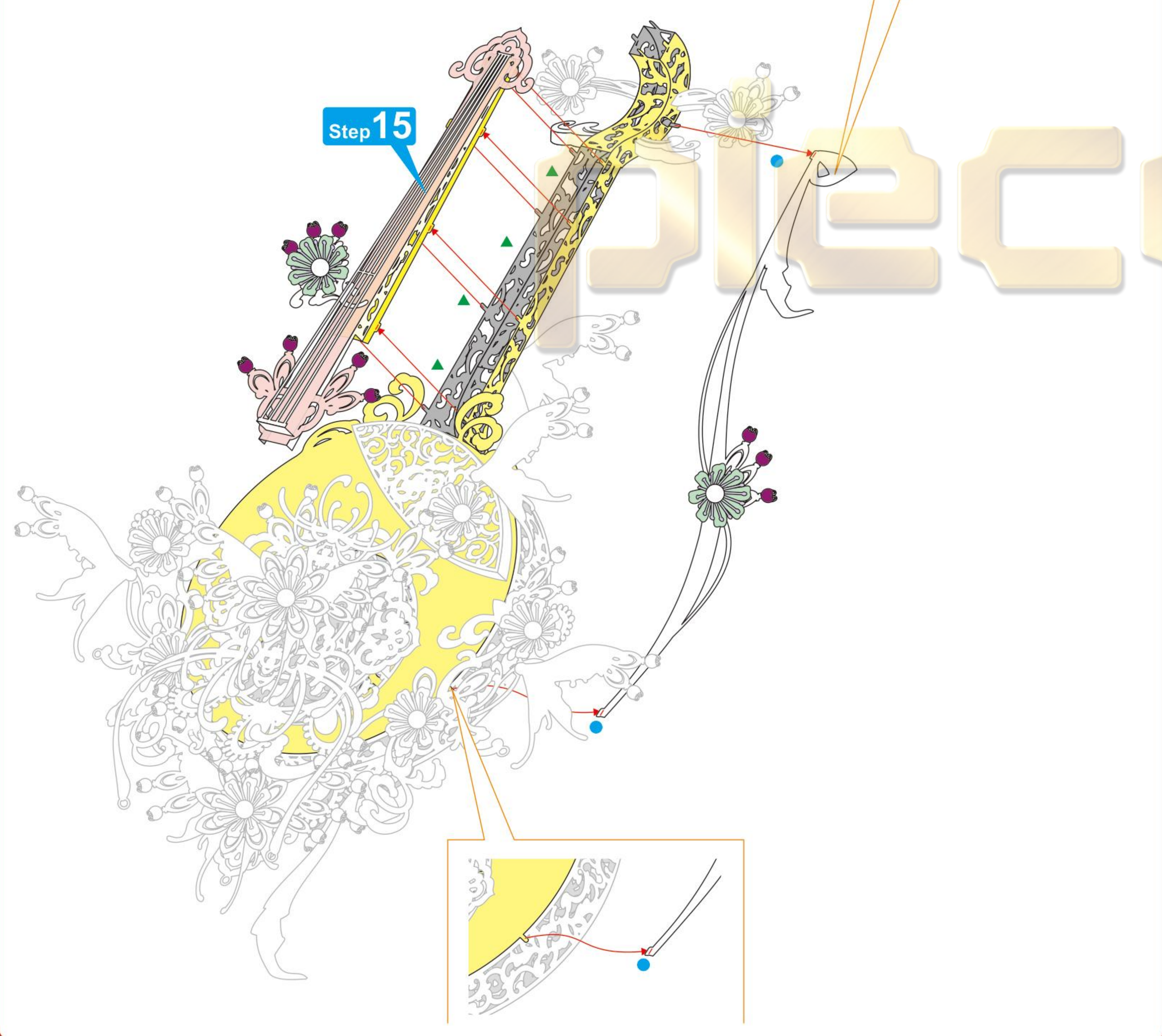
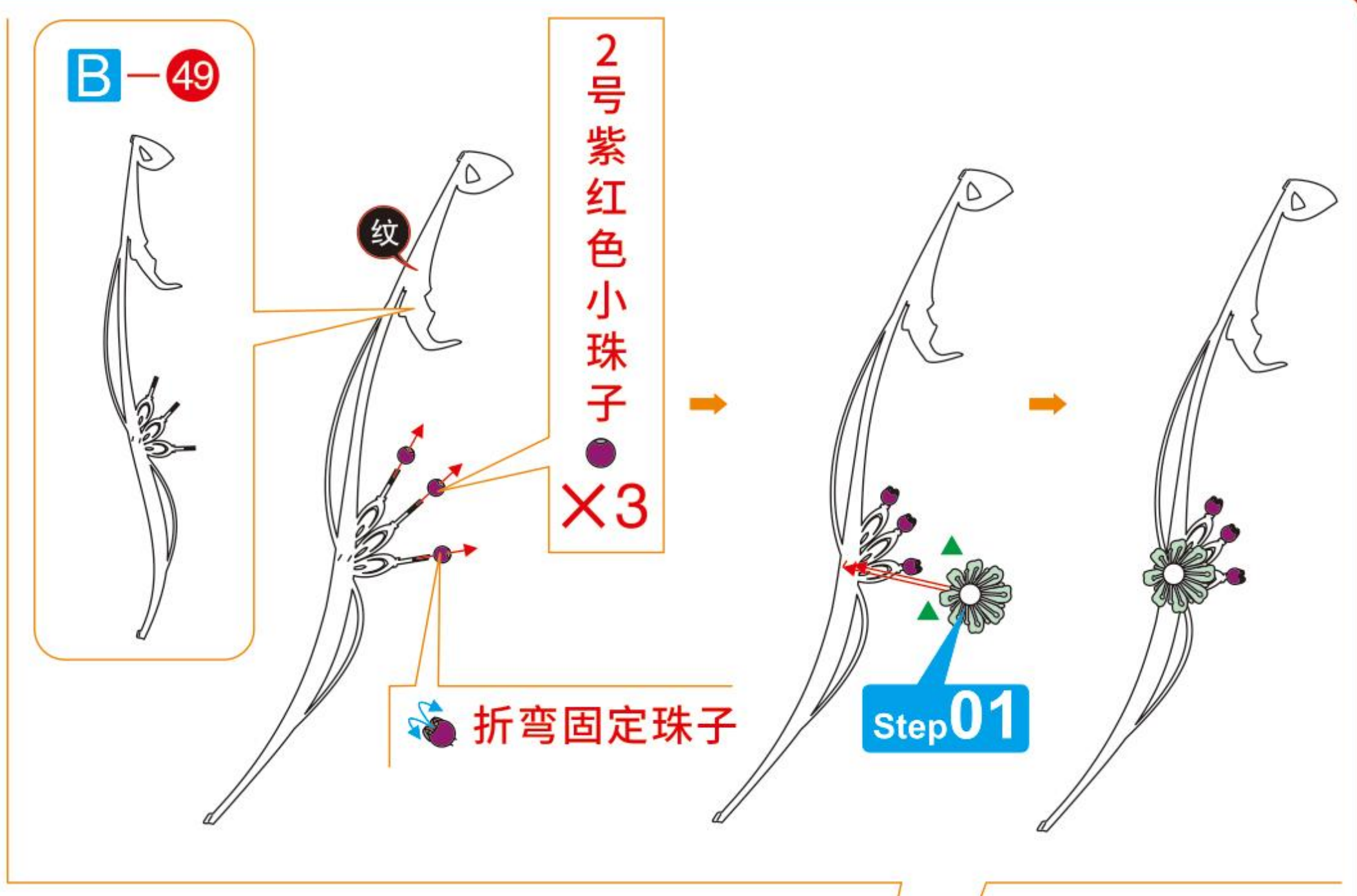

9 10
11 12

